



GROVJOINT INDIA PIPE FITTINGS



DUCTILE IRON GROOVED FITTINGS AND COUPLINGS

0461 - 2900568



info@grovejointindia.com



1st floor, 4/28 E-2,
KMA Warehousing Complex, Tuticorin





Company Profile	1
Certificates	2 & 3
Rigid Coupling - GJRC50G	4
Flexible Coupling - GJFC12G	5
Flexible Coupling (Large Size)- GJFC12L, Rigid Coupling (Large Size) - GJRC50L	6
Flexible Coupling heavy - GJFC11G	7
Grooved Reducing Coupling - GJRC25G	8
Grooved Elbow 90° Long - GJ1090L	9
Grooved Elbow 90° Short - GJ1590S	10
Grooved Elbow 45° - GJ1645S	11
Grooved Elbow 22.5° - GJ1222R	12
Grooved Elbow 11.25° - GJ1311R	13
Grooved Equal Tee Long Radius - GJET11L	14
Grooved Equal Tee Short Radius - GJET17S	15
Grooved Cross Tee - GJXT35G	16
U-Bolt Mechanical Tee - GJMT13U	17
Mechanical Tee Grooved - GJMT15G	18 & 19
Mechanical Tee Threaded - GJMT16T	20 & 21
Grooved Concentric Reducer - GJCR40G	22 & 23
Grooved Concentric Reducer Threaded - GJCR40T	24 & 25
Reducing Tee Grooved - GJRT15G	26 & 27
Reducing Tee Threaded - GJRT15T	28 & 29
Grooved Eccentric Reducer (Grooved Ends) - GJER45G	30
Flanges	31
Flange Adapters	32
End Caps	33
Gasket Data	34
Rigid and Flexible Coupling Features	35
Coupling Installation Instructions	36
Mechanical Tee Features	37
Mechanical Tee Installation Instructions	38 & 39
Roll Grooving Dimensions	40 & 41
Cut Grooving Dimensions	42
Terms and Conditions	43

GROVJOINT INDIA PIPE FITTINGS was set up upon a dream, quality, and vision to provide infrastructure, fire protection, and building services industries with a remarkable range of premium products of grooved pipe fittings. Its mission is to serve the customer requirements in a superior manner by adopting a unique quantitative way with the help of advanced technology. The organization's vision is to be one of the leading manufacturers and providers of Ductile Iron Pipe Fittings in the Asian Sub Continent.

Our highest standard of ethics, quality, and service has acquired us a high reputation, faithfulness, and trust of our customers who have since become our long-term accomplices. Subsequently, we just measure our prosperity depends on the total fulfillment and loyalty of our esteemed clients.

One of our fundamental beliefs is straightforwardness. We are continually imparting significant data to our current and forthcoming clients. In any market, it is essential to keep our finger on the beat and educate our clients about the advancements, innovation, and accordingly regarding them as accomplices in our organization. We do our absolute best to keep you educated to empower you to settle on sound and thoroughly examined choices with the help of our fully experienced and professional staff.

FEATURES

Reliable

The couplings engages around both ends of the pipe and keeps the pipe ends under control from separation from pressure and other forces unto the maximum rated coupling pressure.

Reduced Cost

The installation process for the products are quick and easy. Installation does not require special training and the installation prices are controllable.

Rigidity

The products are rigid for all type of usage and are under standard specification.

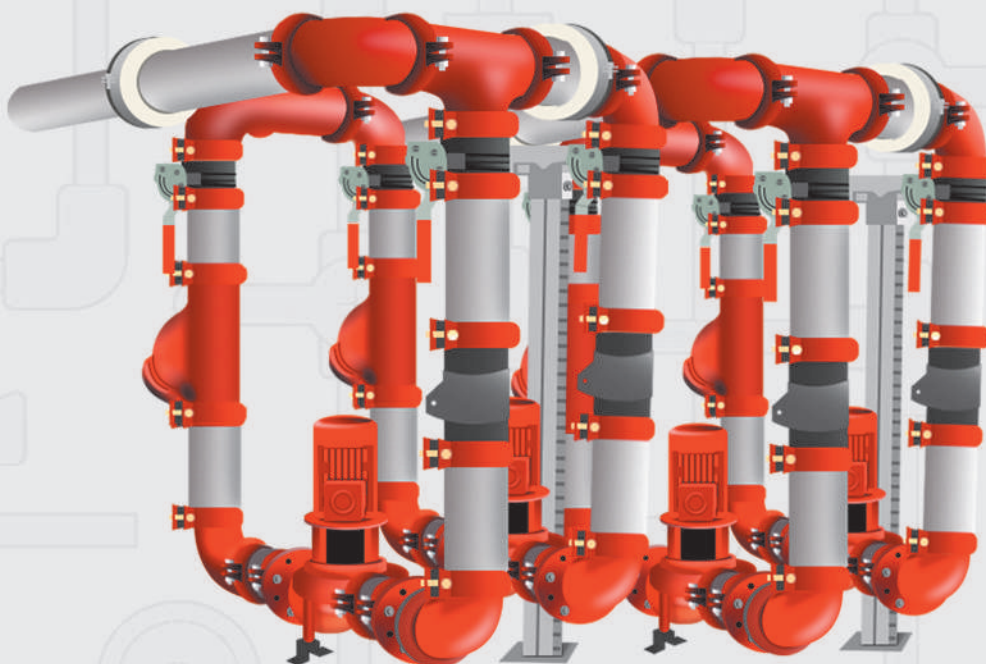



CERTIFICATE OF COMPLIANCE

Certificate Number EX28552
Report Reference EX28552-20210320
Issue Date 2021-April-09

Issued to: Grovjoint India Pipe Fittings
1st Floor, No. 4/28 E-2, K.M.A. Warehousing Complex,
Harbour Bye Pass Road, Tuticorin Thoothukudi
Tamil Nadu 628006IN

This certificate confirms that representative samples of Fittings, Grooved and Plain End
See Addendum Page

Have been investigated by UL in accordance with the Standard(s) indicated on this Certificate.

Standard(s) for Safety: Subject 213C Outline of Investigation for Grooved and Plain End Fittings

Additional Information: See the UL Online Certifications Directory at <https://iq.ulprospector.com> for additional information.

This Certificate of Compliance does not provide authorization to apply the UL Mark. Only the UL Follow-Up Services Procedure provides authorization to apply the UL Mark.

Only those products bearing the UL Mark should be considered as being UL Certified and covered under UL's Follow-Up Services.

Look for the UL Certification Mark on the product.

Barry
Bruce Maheshwari, Director North American Certification Program
UL LLC



CERTIFICATE OF COMPLIANCE

Certificate Number EX28551
Report Reference EX28551-20210323
Issue Date 2021-APRIL-09

Issued to: GROVJOINT INDIA PIPE FITTINGS
1st Floor, No. 4/28 E-2, K.M.A. Warehousing Complex,
Harbour Bye Pass Road, Tuticorin
Thoothukudi, Tamil Nadu, 628006 IN

This certificate confirms that representative samples of FITTINGS, RUBBER GASKETED
See addendum page for models

Have been investigated by UL in accordance with the Standard(s) indicated on this Certificate.

Standard(s) for Safety: ANSI/CAN/UL 213 - UL Standard for Rubber Gasketed Fittings for Fire Protection Service

Additional Information: See the UL Online Certifications Directory at <https://iq.ulprospector.com> for additional information.

This Certificate of Compliance does not provide authorization to apply the UL Mark. Only the UL Follow-Up Services Procedure provides authorization to apply the UL Mark.

Only those products bearing the UL Mark should be considered as being UL Certified and covered under UL's Follow-Up Services.

Look for the UL Certification Mark on the product.

Barry
Bruce Maheshwari, Director North American Certification Program
UL LLC



Certificate of Compliance

This certificate is issued for the following:
Gasketed and Non-Gasketed Pipe Fittings for Aboveground Fire Protection Systems

Prepared for:
GROVJOINT INDIA PIPE FITTINGS
1st Fl, No. 4/28 E-2 KMA Warehousing Complex,
Harbour Bye Pass Rd
Thoothukudi, Tamil Nadu 628006
India

FM Approvals Class: 1920 – "Pipe Couplings and Fittings for Aboveground Fire Protection Systems"
(November, 2007)

Approval Identification: PR459601 Approval Granted: April 30, 2021

To verify the availability of the Approved product, please refer to www.approvalguide.com

Said Approval is subject to satisfactory field performance, continuing Surveillance Audits, and strict conformity to the constructions as shown in the Approval Guide, an online resource of FM Approvals.



David Fuller
David Fuller
VP - Manager of Fire Protection
FM Approvals
1151 Boston-Providence Turnpike
Norwood, MA 02062



شهادة گرو جوائنڈہ سرٹیفیکٹ CERTIFICATE CERTIFICATO CERTIFICADO CERTIFIKAT



CERTIFICATE

GROVJOINT INDIA PIPE FITTINGS PRIVATE LIMITED
 ADDRESS: NO.4/28 E, K.M.A WAREHOUSING COMPLEX, HARBOUR BYE PASS ROAD, THOOTHUKUDI, TAMIL NADU - 628006, INDIA

Certify that the environmental management system of the above organization has been audited and found to be in accordance with the requirements of standard detailed below

ISO 14001:2015

For The Following Scope

MANUFACTURE AND SUPPLY OF GROOVED DUCTILE IRON PIPE FITTINGS AND COUPLINGS

Certificate No:- QAIS-E-IND-GI-01.23.003
EA Code: 18

*This certificate is issued in accordance with the QACS International Pvt. Ltd. auditing and Certification procedures and it is remain valid subject to annual surveillance audit.

Certificate Issue Date: 3rd March 2023 1st Surveillance Date: 2nd February 2024
 Date of Initial Registration: 3rd March 2023 2nd Surveillance Date: 2nd February 2025
 Certificate Validity: 3 Years *Expiry Date: 2nd February 2026

Note: Certificate shall be valid after surveillance, only if continuation letter by QACS is present.

To Check the certificate validity please
Refer Web:- www.qacsworld.com

*Disclaimer - This certificate is issued on the basis of random onsite inspection v.v. System/Product Certification of organization as per the standard mentioned. This Certificate do not involve any financial auditing. This certificate cannot be used as justification for raising any type of deposit scheme. QACS will not be responsible if someone give deposit/scheme based on this System/Product certification mentioning it as an investment financial audit.





IAS
ACCREDITED
International Society
Certification Body
MSCB-150

QACS International Pvt. Ltd.
101 Lullabai, Regency, 43 000 Palam, New Delhi, India

 Authorised Signatory

QACS INTERNATIONAL PVT. LTD.
 info@qacertification.asia, operationqacs@gmail.com, officeqacs@gmail.com
 www.qacsworld.com

شهادة گرو جوائنڈہ سرٹیفیکٹ CERTIFICATE CERTIFICATO CERTIFICADO CERTIFIKAT



CERTIFICATE

GROVJOINT INDIA PIPE FITTINGS PRIVATE LIMITED
 ADDRESS: NO.4/28 E, K.M.A WAREHOUSING COMPLEX, HARBOUR BYE PASS ROAD, THOOTHUKUDI, TAMIL NADU - 628006, INDIA

Certify that the occupational health management system of the above organization has been audited and found to be in accordance with the requirements of standard detailed below

ISO 45001:2018

For The Following Scope

MANUFACTURE AND SUPPLY OF GROOVED DUCTILE IRON PIPE FITTINGS AND COUPLINGS

Certificate No:- QAIS-OH-IND-GI-01.23.003
EA Code: 18

*This certificate is issued in accordance with the QACS International Pvt. Ltd. auditing and Certification procedures and it is remain valid subject to annual surveillance audit.

Certificate Issue Date: 3rd March 2023 1st Surveillance Date: 2nd February 2024
 Date of Initial Registration: 3rd March 2023 2nd Surveillance Date: 2nd February 2025
 Certificate Validity: 3 Years *Expiry Date: 2nd February 2026

Note: Certificate shall be valid after surveillance, only if continuation letter by QACS is present.

To Check the certificate validity please
Refer Web:- www.qacsworld.com

*Disclaimer - This certificate is issued on the basis of random onsite inspection v.v. System/Product Certification of organization as per the standard mentioned. This Certificate do not involve any financial auditing. This certificate cannot be used as justification for raising any type of deposit scheme. QACS will not be responsible if someone give deposit/scheme based on this System/Product certification mentioning it as an investment financial audit.





IAS
ACCREDITED
International Society
Certification Body
MSCB-150

QACS International Pvt. Ltd.
101 Lullabai, Regency, 43 000 Palam, New Delhi, India



 Authorised Signatory

QACS INTERNATIONAL PVT. LTD.
 info@qacertification.asia, operationqacs@gmail.com, officeqacs@gmail.com
 www.qacsworld.com



Certificate

Standard	ISO 9001:2015
Certificate Registr. No.	01 100 2337308
Certificate Holder:	GROVJOINT INDIA PIPE FITTINGS PRIVATE LIMITED Second Floor, No.4/28,E-2,K.M.A Warehousing Complex, Harbour Bye Pass Road, Thoothukudi - 628006, Tamilnadu, India
Scope:	Manufacture of Grooved Ductile Iron Pipe Fittings and Couplings.
Validity:	The certificate is valid from 2023-03-27 until 2026-03-26. First certification 2023

2023-03-27

 TÜVRheinland Cert GmbH
 Am Grauen Stein · 51105 Köln

www.tuv.com

DAkkS
Deutscher
Akademischer
Vereinigung
D 30-10033 01-00



TÜVRheinland®
Precisely Right.

TÜV, IZET and TÜV are registered trademarks. Ownership and application requires your approval.



RIGID COUPLING - GJRC50G

- The couplings provide severity for internal pressure applications. They are designed for fire protection and other related grooved piping systems.
- It provides a restrained connection that combats various types of loads.
- Coupling housing are made up of ductile iron conforming to ASTM A536 and the rubber gaskets are made by EPDM with rated working pressure up to 500 psi.
- They feature high pressure ratings.
- Available with hot dipped galvanised coating as optional

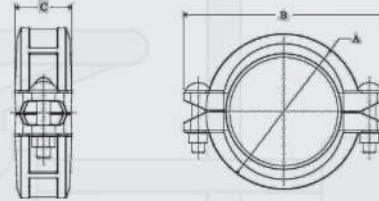

Normal Size mm/in	Pipe O.D mm/in	Working Pressure PSI/MPa	Bolt Size No-Size mm	Dimensions mm/in		
				O	L	H
25	33.7	500	2-M10x45	60	102	45
1	1.327	3.45	2-M10x45	2.362	4.016	1.772
32	42.4	500	2-M10x45	70	106	44
1 1/4	1.669	3.45	2-M10x45	2.756	4.173	1.732
40	48.3	500	2-M10x45	73	108	44
1 1/2	1.900	3.45	2-M10x45	2.874	4.252	1.732
50	60.3	500	2-M10x55	87	123	44
2	2.375	3.45	2-M10x55	3.425	4.843	1.732
65	73.0	500	2-M10x55	100	138	44
2 1/2	2.875	3.45	2-M10x55	3.937	5.433	1.732
65	76.1	500	2-M10x55	103	142	45
2 1/2	3.000	3.45	2-M10x55	4.055	5.591	1.772
80	88.9	500	2-M12x60	117	166	45
3	3.500	3.45	2-M12x60	4.606	6.535	1.772
100	114.3	500	2-M12x65	139	190	49
4	4.500	3.45	2-M12x65	5.472	7.480	1.929
125	139.7	400	2-M12x75	168	218	49
5	5.500	2.75	2-M12x75	6.614	8.583	1.929
125	139.7	500	2-M16x85	170	233	52
5	5.500	3.45	2-M16x85	6.692	9.173	2.047
125	141.3	400	2-M12x75	167	219	49
5	5.563	2.75	2-M12x75	6.575	8.622	1.929
125	141.3	500	2-M16x85	170	235	52
5	5.563	3.45	2-M16x85	6.692	9.251	2.047
150	165.1	400	2-M12x75	193	241	49
6	6.500	2.75	2-M12x75	7.598	9.488	1.929
150	165.1	500	2-M16x85	199	256	54
6	6.500	3.45	2-M16x85	7.834	10.078	2.125
150	168.3	400	2-M12x75	198.5	249	50
6	6.625	2.75	2-M12x75	7.815	9.803	1.969
150	168.3	500	2-M16x85	206	263	54
6	6.625	3.45	2-M16x85	8.110	10.354	2.125
200	219.1	300	2-M16x85	253	320	59
8	8.625	2.07	2-M16x85	9.961	12.598	2.323
200	219.1	500	2-M20x120	258	336	63
8	8.625	3.45	2-M20x120	10.157	13.228	2.480
250	273	300	2-M22x130	335	426	68
10	10.748	2.07	2-M22x130	13.189	16.772	2.677
250	273.0	500	2-M24x130	322	410	65
10	10.748	3.45	2-M24x130	12.677	16.141	2.559
300	323.9	300	2-M22x130	380	470	65
12	12.752	2.07	2-M22x130	14.96	18.504	2.559
300	323.9	500	2-M24x130	384	472	66
12	12.752	3.45	2-M24x130	15.118	18.582	2.598

Flexible Coupling - GJFC12G



- They are ductile iron grooved flexible coupling designed for fire protection and other related grooved piping systems. They are designed in a way to withstand pressure applications at lighter weights.
- The flexible couplings are designed to accommodate more angular movement and axial displacement for better flexibility of installation.
- They provide better protection in seismic events and helps to reduce noise and vibration.
- The flexible couplings are made up of ductile iron conforming to ASTM A536 and the rubber gaskets are made by EPDM with rated working pressure up to 500 psi.
- Available with hot dipped galvanised coating as optional

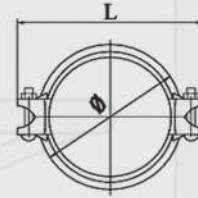

Normal Size mm/in	Pipe O.D mm/in	Working Pressure PSI/MPa	Bolt Size No-Size mm	Allow Pipe end Separation	Max. Deflection from & Center Line			Dimensions		
					in/mm	Per Coup. Deg	Pipe		O	L
				In. /ft			mm/m			
25 1	33.7 1.327	500 3.45	2-M10x45	0-0.06 0-1.6	2° 43'	0.57	48	60 2.362	98 3.858	43.5 1.713
32 1 1/4	42.4 1.669	500 3.45	2-M10x45	0-0.06 0-1.6	2° 10'	0.45	38	67 2.638	106 4.173	44 1.732
40 1 1/2	48.3 1.900	500 3.45	2-M10x45	0-0.06 0-1.6	1° 56'	0.4	33	73 2.874	108 4.252	44 1.732
50 2	60.3 2.375	500 3.45	2xm10x55	0-0.06 0-1.6	1° 31'	0.32	27	87 3.425	123 4.843	44 1.732
65 2 1/2	73.0 2.875	500 3.45	2-M10x55	0-0.06 0-1.6	1° 15'	0.26	22	100 3.937	138 5.433	44 1.732
65 2 1/2	76.1 3.000	500 3.45	2-M10x55	0-0.06 0-1.6	1° 12'	0.26	22	103 4.055	142 5.591	45 1.772
80 3	88.9 3.500	500 3.45	2-M12x60	0-0.06 0-1.6	1° 2'	0.22	18	117 4.606	166 6.535	45 1.772
100 4	114.3 4.500	500 3.45	2-M12x65	0-0.13 0-3.2	1° 36'	0.34	28	139 5.472	190 7.480	49 1.929
125 5	139.7 5.500	400 2.75	2-M12x75	0-0.13 0-3.2	1° 18'	0.28	23	168 6.614	218 8.583	49 1.929
125 5	139.7 5.500	500 3.45	2-M16x85	0-0.13 0-3.2	1° 18'	0.28	23	170 6.692	233 9.173	52 2.047
125 5	141.3 5.563	400 2.75	2xm12x75	0-0.13 0-3.2	1° 18'	0.27	22	167 6.575	219 8.622	49 1.929
125 5	141.3 5.563	500 3.45	2-M16x85	0-0.13 0-3.2	1° 18'	0.27	22	170 6.692	235 9.251	52 2.047
150 6	165.1 6.500	400 2.75	2-M12x75	0-0.13 0-3.2	1° 6'	0.23	19	193 7.598	241 9.488	49 1.929
150 6	165.1 6.500	500 3.45	2-M16x85	0-0.13 0-3.2	1° 6'	0.23	19	199 7.834	256 10.078	54 2.125
150 6	168.3 6.625	400 2.75	2-M12x75	0-0.13 0-3.2	1° 5'	0.23	19	198.5 7.815	249 9.803	50 1.969
150 6	168.3 6.625	500 3.45	2-M16x85	0-0.13 0-3.2	1° 5'	0.23	19	206 8.110	263 10.354	54 2.125
200 8	219.1 8.625	300 2.07	2-M16x85	0-0.13 0-3.2	0° 50'	0.18	15	253 9.961	320 12.598	59 2.323
200 8	219.1 8.625	500 3.45	2-M20x120	0-0.13 0-3.2	0° 50'	0.18	15	258 10.157	336 13.228	63 2.480
250 10	273 10.748	300 2.07	2-M22x130	0-0.13 0-3.2	0° 40'	0.28	23	317 12.48	401 15.787	63 2.48
250 10	273.0 10.748	500 3.45	2-M24x130	0-0.13 0-3.2	0° 40'	0.28	23	322 12.677	410 16.141	65 2.559
300 12	323.9 12.752	300 2.07	2-M22x130	0-0.13 0-3.2	0° 34'	0.24	20	375 14.764	455 17.913	64 2.52
300 12	323.9 12.752	500 3.45	2-M24x130	0-0.13 0-3.2	0° 34'	0.24	20	384 15.118	472 18.582	66 2.598

Flexible Coupling (Large Size)- GJFC12L

- They are ductile iron grooved flexible coupling designed for fire protection and other related grooved piping systems. they are designed in a way to withstand pressure applications at lighter weights.
- The flexible couplings are designed to accommodate more angular movement and axial displacement for better flexibility of installation.
- They provide better protection in seismic events and helps to reduce noise and vibration.
- The flexible couplings are made up of ductile iron conforming to ASTM A536 and the rubber gaskets are made by EPDM with rated working pressure up to 500 psi.
- Available with hot dipped galvanized coating as optional.

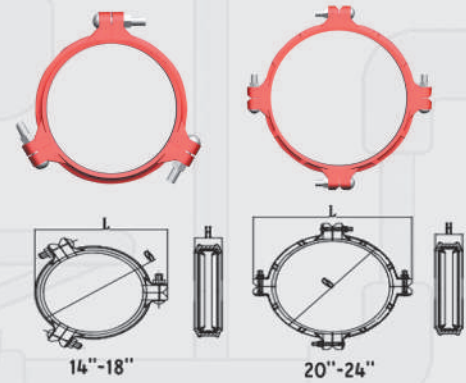

Normal Size mm/in	Pipe O.D mm/in	Working Pressure PSI/MPa	Allow Pipe End Separation	Max. Deflection from & Center Line			Bolt Size No-Size mm	Dimensions			
				In/mm	Per Coup. Deg	Pipe		O	L	H	
						In. /ft					mm/m
350 14	355.6 14.00	300 2.07	0-0.13 0-3.2	0° 31'	0.22	18	3-M22x100	406 15.984	454 17.874	75 2.953	
400 16	406.4 16.00	250 1.72	0-0.13 0-3.2	0°27'	0.19	16	3-M22x100	458 18.031	507 19.961	75 2.953	
450 18	457.2 18.00	250 1.72	0-0.13 0-3.2	0°24'	0.17	14	3-M22x100	507 19.961	535 21.063	82 3.228	
500 20	508 20.00	250 1.72	0-0.13 0-3.2	0°22'	0.15	12	4-M24x130	564 22.205	663 26.102	79 3.11	
600 24	610 24.00	250 1.72	0-0.13 0-3.2	0°18'	0.13	11	4-M24x130	672 26.457	774 30.472	79 3.11	

Rigid Coupling (Large Size) - GJRC50L

- The couplings provide severity for internal pressure applications. They are designed for fire protection and other related grooved piping systems.
- It provides a restrained connection that combats various types of loads.
- Coupling housing are made up of Ductile Iron conforming to ASTM A536 and the rubber gaskets are made by EPDM with rated working pressure up to 500 PSI.
- They feature high pressure ratings.
- Available with hot dipped galvanized coating as optional.

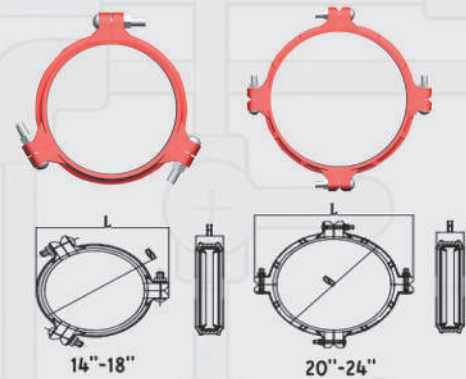

Normal Size mm/in	Pipe O.D mm/in	Working Pressure PSI/MPa	Bolt Size No-Size mm	Dimensions		
				O	L	H
350 14	355.6 14.00	300 2.07	3-M22x100	406 15.984	461 18.15	75 2.953
400 16	406.4 16.00	300 2.07	3-M22x100	458.6 18.055	513.8 20.228	75 2.953
450 18	457.2 18.00	250 1.72	3-M22x100	515 20.276	571 22.48	82 3.228
500 20	508 20.00	250 1.72	4-M24x130	565 22.244	690 27.165	79 3.11
600 24	610 24.00	250 1.72	4-M24x130	676 26.614	786.6 30.969	79 3.11



- They are ductile iron grooved flexible coupling designed for fire protection and other related grooved piping systems. They are designed in a way to withstand pressure applications at lighter weights.
- The flexible couplings are designed to accommodate more angular movement and axial displacement for better flexibility of installation.
- They provide better protection in seismic events and helps to reduce noise and vibration.
- The flexible couplings are made up of ductile iron conforming to ASTM A536 and the rubber gaskets are made by EPDM with rated working pressure up to 500 psi.
- Available with hot dipped galvanised coating as optional

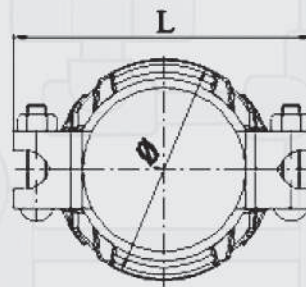

Normal Size mm/in	Pipe O.D mm/in	Working Pressure PSI/MPa	Bolt Size No-Size mm	Allow Pipe End Separation	Max. Deflection from & Center Line			Dimensions mm/in			
					in/mm	Per Coup. Deg	Pipe		O	L	H
							In. /ft	mm/m			
50 2	60.3 2.375	500 3.45	2-1/2x60	0-0.06 0-1.6	1° 31'	0.62	52	44 1.732	136 5.354	46 1.811	
80 3	88.9 3.500	500 3.45	2-1/2x75	0-0.06 0-1.6	1° 2'	0.43	36	59 2.323	161 6.339	46 1.881	
100 4	114.3 4.500	500 3.45	2-5/8x85	0-0.13 0-3.2	1° 36'	0.67	56	74 2.913	204 8.031	51 2.008	
150 6	168.3 6.625	500 3.45	2-3/4x120	0-0.13 0-3.2	1° 5'	0.46	38	103 4.055	270 10.630	54 2.126	
200 8	219.1 8.625	400 2.76	2-7/8x127	0-0.13 0-3.2	0° 50'	0.34	29	135 5.331	355 13.976	64 2.520	
250 10	273 10.75	400 2.76	2-1x165	0-0.13 0-3.2	0° 40'	0.28	23	163 6.417	418 16.457	67 2.638	
300 12	323.9 12.75	400 2.76	2-1x165	0-0.13 0-3.2	0° 34'	0.24	20	189 7.441	464 18.268	68 2.677	



- Grovjoint india couplings are designed to reduce the diameter of pipes.
- These couplings eliminate the need for concentric reducers and additional couplings.
- The rubber gasket and steel plate prevents the telescoping of small pipe towards the larger pipe in vertical assembly.
- Reducer coupling helps to accommodate more angular movement and axial displacement for better flexibility of installations.
- Reducer coupling provides protection from seismic events and helps to reduce vibration and noise.
- Reducing coupling are made of ductile iron conforming to ASTM A536 and the rubber gaskets are made by EPDM with rated working pressure up to 500 psi.
- Available with hot dipped galvanised coating as optional

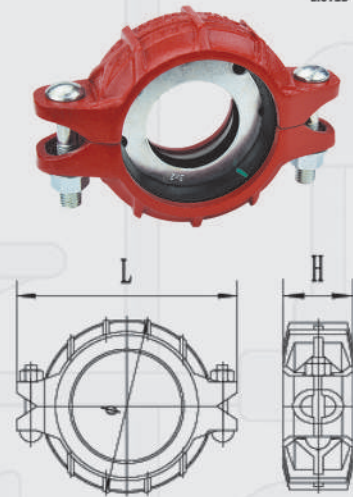

Normal Size mm/in	Pipe O.D mm/in	Working Pressure PSI/MPa	Bolt Size No-Size mm	Max. Deflection from & Center Line			Dimensions mm/in		
				Per Coup. Deg	Pipe		O	L	H
					In. /ft	mm/m			
50*40 2*1/5	60.3*48.3 2.375*1.900	300 2.07	2-M10 x 55	1°-53'	0.4	33	90 3.543	129 5.079	47 1.850
65*40 2 1/2*1/12	73.0*48.3 2.874*1.900	300 2.07	2-M10 x 55	1°-33'	0.32	27	101 3.976	137 5.394	48 1.890
65*50 2/12*2	73.0*60.3 2.874*2.375	300 2.07	2-M10 x 55	1°-33'	0.32	27	101 3.976	137 5.394	48 1.890
65*40 2/12*1 1/2	76.1*48.3 2.996*1.900	300 2.07	2-M10 x 55	1°-33'	0.32	27	105 4.134	140 5.512	48 1.890
65*50 2*2	76.1*60.3 2.996*2.375	300 2.07	2-M10 x 55	1°-33'	0.32	27	105 4.134	140 5.512	48 1.890
80*40 3*1 1/2	88.9*48.3 3.500*1.900	300 2.07	2-M12 x 65	1°-33'	0.32	27	120 4.724	164 6.457	48 1.890
80*50 3*2	88.9*60.3 3.500*2.375	300 2.07	2-M12 x 65	1°-17'	0.26	22	120 4.724	164 6.457	48 1.890
80*65 3*2 1/2	88.9*73.0 3.500*2.874	300 2.07	2-M12 x 65	1°-17'	0.26	22	120 4.724	164 6.457	48 1.890
80*65 3*2 1/2	88.9*76.1 3.500*2.996	300 2.07	2-M12 x 65	1°-17'	0.26	22	120 4.724	164 6.457	48 1.890
100*40 4*1 1/2	114.3*48.3 4.500*1.900	300 2.07	2-M12 x 65	2°-38'	0.55	46	150 5.906	195 7.677	49 1.929
100*50 4*2	114.3*60.3 4.500*2.375	300 2.07	2-M12 x 65	2°-38'	0.55	46	150 5.906	195 7.677	49 1.929
100*65 4*2 1/2	114.3*73 4.500*2.874	300 2.07	2-M12 x 65	2°-38'	0.55	46	150 5.906	195 7.677	49 1.929
100*65 4*2 1/2	114.3*76.1 4.500*2.996	300 2.07	2-M12 x 65	2°-38'	0.55	46	150 5.906	195 7.677	49 1.929
100*80 4*3	114.3*88.9 4.500*3.500	300 2.07	2-M12 x 65	2°-38'	0.55	46	150 5.906	195 7.677	49 1.929
150*100 6*4	165.1*114.3 6.500*4.500	300 2.07	2-M12 x 75	1°-44'	0.38	32	203 7.992	235 9.252	50 1.969
150*80 6*3	168.3*88.9 6.625*3.500	300 2.07	2-M12 x 75	1°-44'	0.38	32	203 7.992	235 9.252	50 1.969
150*100 6*4	168.3*114.3 6.625*4.500	300 2.07	2-M12 x 75	1°-44'	0.38	32	203 7.992	235 9.252	50 1.969
200*150 8*6	219.1*168.3 8.625*6.625	300 2.07	2-M16x100	1°-15'	0.26	22	264 10.394	313 12.323	60 2.362

Grooved Elbow 90 Deg Long - GJ1090L



- They feature less friction loss compared to short radius.
- Grooved elbow are primarily designed for fire protection applications and other related grooved piping systems. It can also be used for general services.
- The elbow housings are made up of Ductile Iron conforming to ASTM A536 and the grooving standards AWWA C606 with rated working pressure up to 500 psi.
- Available with hot dipped galvanised coating as optional

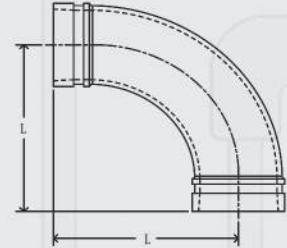

SIZE DN in	Pipe O.D mm/in	Working Pressure PSI/MPa	L mm/in
25 1	33.7 1.315	400 2.75	57 2.24
32 1 ¼	42.4 1.660	400 2.75	70 2.755
40 1 ½	48.3 1.900	400 2.75	70 2.755
50 2	57.0 2.244	400 2.75	83 3.267
50 2	60.3 2.375	400 2.75	83 3.267
65 2 ½	73.0 2.875	400 2.75	95 3.74
65 2 ½	76.1 3.000	400 2.75	95 3.74
80 3	88.9 3.500	400 2.75	108 4.251
100 4	108.0 4.252	400 2.75	127 5
100 4	114.3 4.500	400 2.75	127 5
125 5	133.0 5.250	400 2.75	140 5.511
125 5	139.7 5.500	400 2.75	140 5.511
125 5	141.3 5.563	400 2.75	140 5.511
150 6	159.0 6.260	300 2.07	165 6.496
150 6	165.1 6.500	300 2.07	165 6.496
150 6	168.3 6.625	300 2.07	165 6.496
200 8	219.1 8.625	300 2.07	197 7.755
250 10	273.0 10.750	300 2.07	229 9.015
300 12	323.9 12.750	300 2.07	254 10
350 14	377.0 14.843	300 2.07	



- Grovjoint elbows 90 are designed to provide uniform flow and minimal pressure drop.
- They are primarily designed for fire protection applications and other related grooved piping systems. It can be also used for general services.
- Elbow housings are made up of Ductile Iron conforming to ASTM A536 and the grooving standards AWWA C606 with rated working pressure up to 500 psi.
- Available with hot dipped galvanised coating as optional

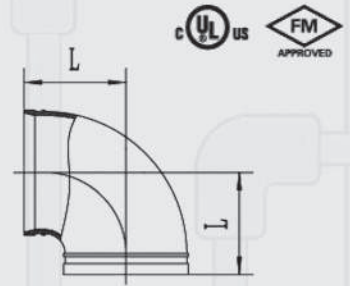

SIZE DN in	Pipe O.D mm/in	Working Pressure PSI/MPa	L mm/in
25	33.7	400	57
1	1.315	2.75	2.244
32	42.4	400	60
1 ¼	1.660	2.75	2.362
40	48.3	400	60
1 ½	1.900	2.75	2.362
50	57.0	400	70
2	2.244	2.75	2.755
50	60.3	400	70
2	2.375	2.75	2.755
65	73.0	400	76
2 ½	2.875	2.75	2.992
65	76.1	400	76
2 ½	3.000	2.75	2.992
80	88.9	400	86
3	3.500	2.75	3.386
100	108.0	400	101.5
4	4.252	2.75	3.996
100	114.3	400	101.5
4	4.500	2.75	3.996
125	133.0	400	122
5	5.250	2.75	4.803
125	139.7	400	122
5	5.500	2.75	4.803
125	141.3	400	122
5	5.563	2.75	4.803
150	159.0	300	140
6	6.260	2.07	5.511
150	165.1	300	140
6	6.500	2.07	5.511
150	168.3	300	140
6	6.625	2.07	5.511
200	219.1	300	175
8	8.625	2.07	6.889
250	273.0	300	215
10	10.750	2.07	8.464
300	323.9	300	245
12	12.750	2.07	9.645
350	377.0	300	280
14	14.843	2.07	11.024

Grooved Elbow 45 Deg - GJ1645S



- Grooved elbow 45° features short center to end dimensions and it helps easier installations in less space.
- They are primarily designed for fire protection applications and other related grooved piping system, it can also be used for general services.
- Elbow housings are made of Ductile Iron conforming to ASTM A536 and the grooving standards AWWA C606 with rated working pressure up to 500 psi.
- Available with hot dipped galvanised coating as optional

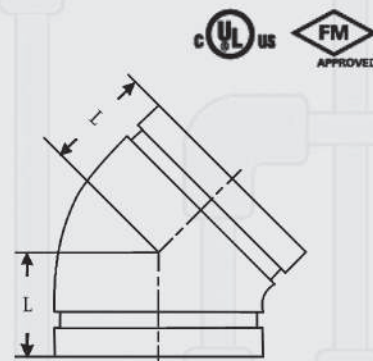

SIZE DN in	Pipe O.D mm/in	Working Pressure PSI/MPa	L mm/in
25	33.7	400	38
1	1.315	2.75	1.496
32	42.4	400	44
1 ¼	1.660	2.75	1.732
40	48.3	400	44
1 ½	1.900	2.75	1.732
50	60.3	400	51
2	2.375	2.75	2.007
65	73.0	400	57
2 ½	2.875	2.75	2.244
65	76.1	400	57
2 ½	3.000	2.75	2.244
80	88.9	400	64
3	3.500	2.75	2.519
100	108.0	400	76
4	4.252	2.75	2.992
100	114.3	400	76
4	4.500	2.75	2.992
125	133.0	400	83
5	5.250	2.75	3.267
125	139.7	400	83
5	5.500	2.75	3.267
125	141.3	400	83
5	5.563	2.75	3.267
150	159.0	300	89
6	6.260	2.07	3.503
150	165.1	300	89
6	6.500	2.07	3.503
150	168.3	300	89
6	6.625	2.07	3.503
200	219.1	300	108
8	8.625	2.07	4.251
250	273.0	300	121
10	10.750	2.07	4.763
300	323.9	300	133
12	12.750	2.07	5.236



Grooved Elbow 22.5 Deg - GJ1222R

- Grooved elbow 22.5° features short center to end dimensions and it helps easier installations in less space.
- They are primarily designed for fire protection applications and other related grooved piping system, it can also be used for general services.
- Elbow housings are made of Ductile Iron confirming to ASTM A536 and the grooving standards AWWA C606 with rated working pressure up to 500 psi.
- Available with hot dipped galvanised coating as optional

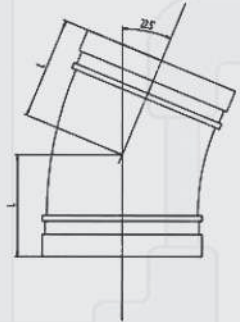

SIZE DN in	Pipe O.D mm/in	Working Pressure PSI/MPa	L mm/in
25	33.7	400	41
1	1.315	2.75	1.61
32	42.4	400	44
1 ¼	1.660	2.75	1.732
40	48.3	400	44
1 ½	1.900	2.75	1.732
50	60.3	400	51
2	2.375	2.75	2
65	73.0	400	51
2 ½	2.875	2.75	2
65	76.1	400	51
2 ½	3.000	2.75	2
80	88.9	400	57
3	3.500	2.75	2.244
100	108.0	400	73
4	4.252	2.75	2.874
100	114.3	400	73
4	4.500	2.75	2.874
125	133.0	400	73
5	5.250	2.75	2.874
125	139.7	400	73
5	5.500	2.75	2.874
125	141.3	400	73
5	5.563	2.75	2.874
150	159.0	300	79
6	6.260	2.07	3.11
150	165.1	300	79
6	6.500	2.07	3.11
150	168.3	300	79
6	6.625	2.07	3.11
200	219.1	300	98
8	8.625	2.07	3.858
250	273.0	300	111
10	10.750	2.07	4.37
300	323.9	300	124
12	12.750	2.07	4.88

Grooved Elbow 11.25 Deg - GJ1311R



- Grooved elbow features short center to end dimensions and it helps easier installations in less space.
- They are primarily designed for fire protection applications and other related grooved piping system, it can also be used for general services.
- Elbow housings are made of Ductile Iron conforming to ASTM A536 and the grooving standards AWWA C606 with rated working pressure up to 500 psi.
- Available with hot dipped galvanised coating as optional

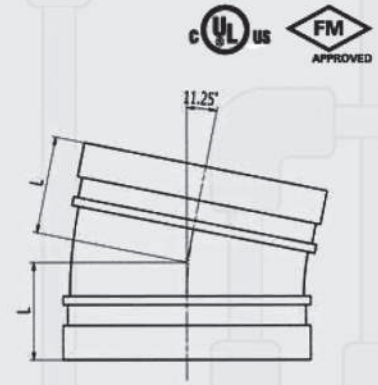

SIZE DN in	Pipe O.D mm/in	Working Pressure PSI/MPa	L mm/in
25	33.7	400	35
1	1.315	2.75	1.377
32	42.4	400	35
1 ¼	1.660	2.75	1.377
40	48.3	400	35
1 ½	1.900	2.75	1.377
50	60.3	400	35
2	2.375	2.75	1.377
65	73.0	400	38
2 ½	2.875	2.75	1.496
65	76.1	400	38
2 ½	3.000	2.75	1.496
80	88.9	400	38
3	3.500	2.75	1.496
100	108.0	400	44
4	4.252	2.75	1.732
100	114.3	400	48
4	4.500	2.75	1.889
125	133.0	400	51
5	5.250	2.75	2.007
125	139.7	400	51
5	5.500	2.75	2.007
125	141.3	400	51
5	5.563	2.75	2.007
150	159.0	300	51
6	6.260	2.07	2.007
150	165.1	300	51
6	6.500	2.07	2.007
150	168.3	300	51
6	6.625	2.07	2.007
200	219.1	300	51
8	8.625	2.07	2.007
250	273.0	300	54
10	10.750	2.07	2.125
300	323.9	300	57
12	12.750	2.07	2.244



- Grovjoint equal tee are designed to join two pipes of equal diameter which are perpendicular to the direction of flow
- They provide minimal pressure drop. They are primarily designed for fire protection applications and other related grooved piping system. It can also be used for general services.
- Grooved tee housings are made up of Ductile Iron confirming to ASTM A536 and the grooving standards AWWA C606 with rated working pressure up to 500 psi.
- Available with hot dipped galvanised coating as optional

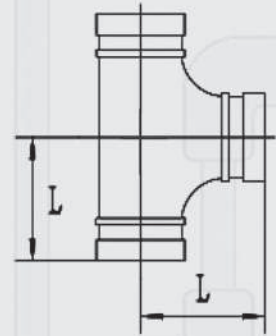

Size DN Inch	Pipe O.D mm/in	Working Pressure PSI/MPa	Dimension L mm/in
25 1	33.7 1.315	400 2.75	57 2.244
32 1 ¼	42.4 1.660	400 2.75	70 2.755
40 1 ½	48.3 1.900	400 2.75	70 2.755
50 2	60.3 2.375	400 2.75	83 3.267
65 2 ½	73.0 2.875	400 2.75	95 3.74
65 2 ½	76.1 3.000	400 2.75	95 3.74
80 3	88.9 3.500	400 2.75	108 4.251
100 4	108.0 4.252	400 2.75	127 5
100 4	114.3 4.500	400 2.75	127 5
125 5	133.0 5.250	400 2.75	140 5.511
125 5	139.7 5.500	400 2.75	140 5.511
125 5	141.3 5.563	400 2.75	140 5.511
150 6	159.0 6.260	300 2.07	165 6.496
150 6	165.1 6.500	300 2.07	165 6.496
150 6	168.3 6.625	300 2.07	165 6.496
200 8	219.1 8.625	300 2.07	197 7.755
250 10	273.0 10.750	300 2.07	229 9.015
300 12	323.9 12.750	300 2.07	254 10

Equal Tee Short Radius - GJET17S



- Grovjoint equal tee are designed to join two pipes of equal diameter which are perpendicular to the direction of flow
- They provide minimal pressure drop. They are primarily designed for fire protection applications and other related grooved piping system. It can also be used for general services.
- Grooved tee housings are made up of Ductile Iron conforming to ASTM A536 and the grooving standards AWWA C606 with rated working pressure up to 500 psi.
- Available with hot dipped galvanised coating as optional

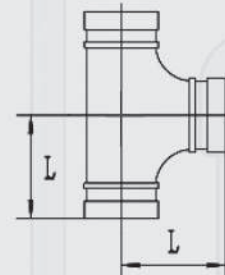

Size DN Inch	Pipe O.D mm/in	Working Pressure PSI/MPa	Dimension L mm/in
25 1	33.7 1.315	400 2.75	57 2.244
32 1 ¼	42.4 1.660	400 2.75	60 2.362
40 1 ½	48.3 1.900	400 2.75	60 2.362
50 2	60.3 2.375	400 2.75	70 2.755
65 2 ½	73.0 2.875	400 2.75	76 2.992
65 2 ½	76.1 3.000	400 2.75	76 2.992
80 3	88.9 3.500	400 2.75	86 3.386
100 4	108.0 4.252	400 2.75	101.5 3.996
100 4	114.3 4.500	400 2.75	101.5 3.996
125 5	133.0 5.250	400 2.75	122 4.803
125 5	139.7 5.500	400 2.75	122 4.803
125 5	141.3 5.563	400 2.75	122 4.803
150 6	159.0 6.260	300 2.07	140 5.511
150 6	165.1 6.500	300 2.07	140 5.511
150 6	168.3 6.625	300 2.07	140 5.511
200 8	219.1 8.625	300 2.07	175 6.889
250 10	273.0 10.750	300 2.07	215 8.464
300 12	323.9 12.750	300 2.07	245 9.645



Grooved Cross Tee - GJXT35G

- Grovjoint cross tee are designed to join same diameter pipes which are perpendicular to the direction of flow.
- They provide minimal pressure drop. They are primarily designed for fire protection applications and other related grooved piping systems. It can also be used for general services.
- Grooved tee housings are made up of Ductile Iron conforming to ASTM A536 with rated working pressure up to 500 psi.
- Available with hot dipped galvanised coating as optional

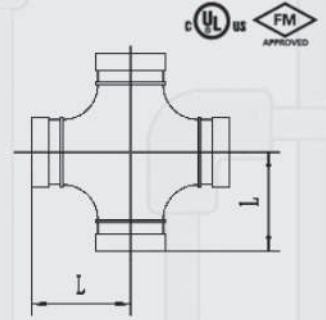

Size DN Inch	Pipe O.D mm/in	Working Pressure PSI/MPa	Dimension L mm/in
50 2	60.3 2.375	400 2.75	70 2.755
65 2 1/2	73.0 2.875	400 2.75	76 2.992
65 2 1/2	76.1 3.000	400 2.75	76 2.992
80 3	88.9 3.500	400 2.75	86 3.386
100 4	108.0 4.252	400 2.75	101.5 3.996
100 4	114.3 4.500	400 2.75	101.5 3.996
125 5	139.7 5.500	400 2.75	122 4.803
150 6	159.0 6.260	300 2.07	140 5.511
150 6	165.1 6.500	300 2.07	140 5.511
150 6	168.3 6.625	300 2.07	140 5.511
200 8	219.1 8.625	300 2.07	175 6.889
250 10	273.0 10.750	300 2.07	215 8.464

- Mechanical tee eliminates need for welding or cuttings of the pipe mains for branch outlets.
- Mechanical Tee housings are made up of Ductile Iron conforming to ASTM A536 and the rubber gaskets are made by EPDM with rated working pressure up to 500 psi.
- Available with hot dipped galvanised coating as optional

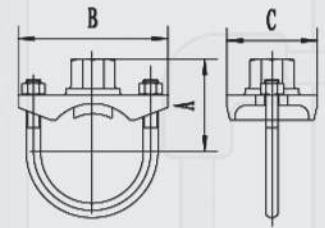

Normal Size mm/in	Pipe O.D mm/in	Working Pressure PSI/MPa	U-Bolt Size No-Size mm	Dimensions mm/in			Hole cutting dimensions mm/in
				A	B	C	
25x15 1x1/2	33.7x21.3 1.327x0.839	300 2.07	M10x25	49 1.929	76 2.992	43 1.654	24 0.945
25x20 1x3/4	33.7x26.9 1.327x1.059	300 2.07	M10x25	58 2.283	84 3.307	43 1.693	24 0.945
32x15 1 1/4x1/2	42.4x21.3 1.669x0.839	300 2.07	M10x28.5	43 1.693	90 3.543	56 2.205	30 1.181
32x20 1 1/4x3/4	42.4x26.9 1.669x1.059	300 2.07	M10x28.5	45 1.772	90 3.543	56 2.205	30 1.181
32x25 1 1/4x1	42.4x33.7 1.669x1.327	300 2.07	M10x28.5	50 1.969	90 3.543	56 2.205	32 1.181
40x15 1 1/2x1/2	48.3x21.3 1.900x0.839	300 2.07	M10x28.5	43 1.693	93 3.661	59 2.323	30 1.181
40x20 1 1/2x3/4	48.3x26.9 1.900x1.059	300 2.07	M10x28.5	54 2.126	93 3.661	59 2.323	30 1.181
40x25 1 1/2x1	48.3x33.7 1.900x1.327	300 2.07	M10x28.5	58 2.283	93 3.661	59 2.323	32 1.181
50x15 2x1/2	60.3x21.3 2.375x0.839	300 2.07	M10x30	54 2.126	96 3.780	59 2.323	30 1.181
50x20 2x3/4	60.3x26.9 2.375x1.059	300 2.07	M10x30	56 2.205	96 3.780	59 2.323	30 1.181
50x25 2x1	60.3x33.7 2.375x1.327	300 2.07	M10x30	66 2.598	96 3.780	59 2.323	32 1.181
65x15 2 1/2x1/2	73.1x21.3 2.878x0.839	300 2.07	M10x30	60 2.362	110 4.331	59 2.323	30 1.181
65x20 2 1/2x3/4	73.1x26.9 2.878x1.059	300 2.07	M10x30	63 2.480	110 4.331	59 2.323	30 1.181
65x25 2 1/2x1	73.1x33.7 2.878x1.327	300 2.07	M10x30	70 2.756	110 4.331	59 2.323	32 1.181
65x15 2 1/2x1/2	76.1x21.3 2.996x0.839	300 2.07	M10x30	61 2.402	110 4.331	59 2.323	30 1.181
65x20 2 1/2x3/4	76.1x26.9 2.996x1.059	300 2.07	M10x30	67 2.638	110 4.331	59 2.323	30 1.181
65x25 2 1/2x1	76.1x33.7 2.847x1.327	300 2.07	M10x30	74 2.913	110 4.331	59 2.323	32 1.181



- Mechanical tees are fast and simple way to provide a grooved connection along the length of the pipe.
- It provides quick and economic connection of smaller branch pipes with cross mains or riser pipes.
- After a hole is drilled in the pipe where in the connection area, just connect the clamps around the pipe for a grooved connection.
- The mechanical tee eliminates the need for welding and the use of multiple fittings.
- Mechanical Tee housings are made of Ductile Iron confirming to ASTM A536 and the rubber gaskets are made by EPDM with rated working pressure up to 500 psi.
- Available with hot dipped galvanised coating as optional

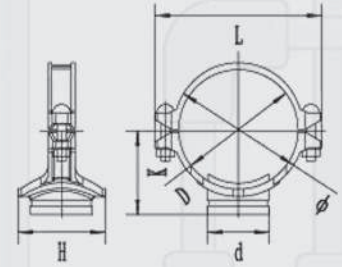

Normal Size mm/in	Pipe O.D mm/in	Working Pressure PSI/MPa	U-Bolt Size No-Size mm	Dimensions mm/in				Hole cutting dimensions mm/in
				O	L	K	H	
50x32 2x1 1/4	60.3x42.4 2.375x1.669	300 2.07	2-M10x55	74 2.913	116 4.566	59 2.322	69 2.716	46 1.811
50x40 2x1 1/2	60.3x48.3 2.375x1.900	300 2.07		78 3.07	116 4.566	59 2.322	69 2.716	46 1.811
65x25 2 1/2 x1	73x33.7 2.87x1.327	300 2.07		93 3.661	144 5.669	70 2.755	77 2.716	38 1.496
65x32 2 1/2 x1 1/4	73x42.4 2.87x1.669	300 2.07		93 3.661	144 5.669	65 2.559	84 3.307	51 2.007
65x40 2 1/2 x1 1/2	73x48.3 2.87x1.900	300 2.07		93 3.661	144 5.669	75 2.952	83 3.267	51 2.007
65x25 2 1/2 x1	76.1x33.7 2.996x1.327	300 2.07		93 3.661	144 5.669	70 2.755	77 2.716	38 1.496
65x32 2 1/2 x1 1/4	76.1x42.4 2.996x1.669	300 2.07		93 3.661	144 5.669	70 2.755	84 3.307	46 1.811
65x40 2 1/2 x1 1/2	76.1x48.3 2.996x1.900	300 2.07		93 3.661	144 5.669	70 2.755	83 3.267	51 2.007
80x25 3x1	88.9x33.7 3.500x1.327	300 2.07	2-M12x60	104 4.094	152 5.984	76 2.755	78 3.070	38 1.496
80x32 3x1 1/4	88.9x42.4 3.500x1.669	300 2.07		104 4.094	152 5.984	76 2.755	82 3.228	46 1.811
80x40 3x1 1/2	88.9x48.3 3.500x1.900	300 2.07		104 4.094	152 5.984	77 2.755	91 3.582	51 2.007
80x50 3x2	88.9x60.3 3.500x2.376	300 2.07		114 4.488	152 5.984	82 3.228	97 2.402	61 2.402
100x25 4x1	114.3x33.7 4.500x1.327	300 2.07		133 5.236	188 7.401	93 3.661	77 3.031	38 1.496
100x32 4x1 1/4	114.3x42.4 4.500x1.669	300 2.07		133 5.236	186 7.322	93 3.661	83 3.267	46 1.811
100x40 4x1 1/2	114.3x48.3 4.500x1.900	300 2.07		133 5.236	186 7.322	93 3.661	92 3.622	51 2.007
100x50 4x2	114.3x60.3 4.500x2.376	300 2.07		140 5.512	188 7.402	93 3.661	97 3.819	61 2.402
100x65 4x2 1/2	114.3x73 4.500x2.874	300 2.07	2-M12x65	140 5.512	180 7.086	98 3.858	103 4.055	70 2.756
100x65 4x2 1/2	114.3x76.1 4.500x2.996	300 2.07		140 5.512	188 7.402	97 3.819	123 4.843	81 3.189
100x80 4x3	114.3x88.9 4.500x3.500	300 2.07		140 5.512	188 7.402	97 3.819	125 4.921	86 3.386
125x25 5x1	139.7x33.7 5.500x1.327	300 2.07		168 6.614	220 8.661	107 4.213	77 3.031	38 1.496
125x32 5x1 1/4	139.7x42.4 5.500x1.669	300 2.07		168 6.614	220 8.661	107 4.213	83 3.268	46 1.811
125x40 5x1 1/2	139.7x48.3 5.500x1.900	300 2.07		168 6.614	220 8.661	107 4.213	92 3.622	51 2.008
125x50 5x2	139.7x60.3 5.500x2.375	300 2.07		168 6.614	220 8.661	107 4.213	97 3.819	61 2.402
125x65 5x2 1/2	139.7x76.1 5.500x2.996	300 2.07		168 6.614	220 8.661	107 4.213	123 4.843	81 3.189
125x80 5x3	139.7x88.9 5.500x3.500	300 2.07	2-M16x75	168 6.614	220 8.661	107 4.213	136 5.354	86 3.386
150x65 6x2 1/2	159.0x76.1 6.260x2.996	300 2.07		168 6.614	220 8.661	107 4.213	123 4.843	81 3.189
150x80 6x3	159.0x88.9 6.260x3.500	300 2.07		187 7.362	242 9.528	117 4.606	136 5.354	86 3.386



- Mechanical tees are fast and simple way to provide a grooved connection along the length of the pipe.
- It provides quick and economic connection of smaller branch pipes with cross mains or riser pipes.
- After a hole is drilled in the pipe where in the connection area, just connect the clamps around the pipe for a grooved connection.
- The mechanical tee eliminates the need for welding and the use of multiple fittings.
- Mechanical Tee housings are made of Ductile Iron confirming to ASTM A536 and the rubber gaskets are made by EPDM with rated working pressure up to 500 psi.
- Available with hot dipped galvanised coating as optional

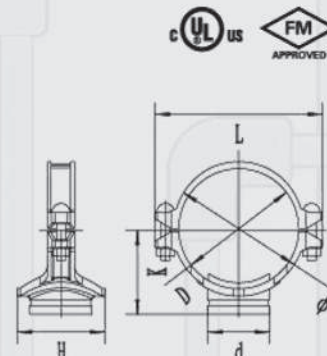

Normal Size mm/in	Pipe O.D mm/in	Working Pressure PSI/MPa	U-Bolt Size No-Size mm	Dimensions mm/in				Hole cutting dimensions mm/in
				O	L	K	H	
150x100 6x4	159.0x108.0 6.260x4.252	300 2.07		187	242	117	134	114
				7.362	9.528	4.606	5.276	4.488
150x100 6x4	159.6x114.3 6.260x4.500	300 2.07		187	242	117	134	114
				7.362	9.528	4.606	5.276	4.488
150x25 6x1	165.1x33.7 6.500x1.900	300 2.07		194	247	123	77	38
				7.638	9.724	4.842	3.031	1.496
150x32 6x1 1/4	165.1x42.4 6.500x1.669	300 2.07		194	247	123	83	46
				7.628	9.724	4.842	3.268	1.811
150x40 6x1 1/2	165.1x48.3 6.500x1.900	300 2.07		194	247	123	92	51
				7.638	9.724	4.842	3.622	2.008
150x50 6x2	165.1x60.3 6.500x2.375	300 2.07		194	247	123	97	61
				7.638	9.724	4.842	3.819	2.402
150x65 6x2 1/2	165.1x76.1 6.500x2.996	300 2.07		194	247	125	123	81
				7.638	9.724	4.921	4.843	9.189
150x80 6x3	165.1x88.9 6.500x3.500	300 2.07		194	247	125	136	86
				7.638	9.724	4.921	5.354	3.386
150x100 6x4	165.1x114.3 6.500x4.500	300 2.07		194	247	125	134	114
				7.638	9.724	4.921	5.276	4.488
150x25 6x1	168.3x33.7 6.625x1.327	300 2.07		198	247	125	77	38
				7.795	9.724	4.921	3.031	1.496
150x32 6x1 1/4	168.3x42.4 6.625x1.669	300 2.07		198	247	128	82	46
				7.795	9.724	5.039	3.228	1.811
150x40 6x1 1/2	168.3x48.3 6.625x1.900	300 2.07		198	247	128	92	51
				7.795	9.724	5.039	3.622	2.007
150x50 6x2	168.3x60.3 8.625x2.375	300 2.07		198	247	128	98	61
				7.795	9.724	5.039	3.858	2.401
150x65 6x2 1/2	168.3x73 6.625x2.874	300 2.07	2-M16x85	198	250	125	108	70
				7.795	9.842	4.921	4.251	2.756
150x65 6x2 1/2	168.3x76.1 6.625x2.996	300 2.07		198	247	128	123	81
				7.795	9.724	5.039	4.843	3.189
150x80 6x3	168.3x88.9 6.625x3.500	300 2.07		198	247	128	136	86
				7.795	9.724	5.030	5.354	3.385
150x100 6x4	168.3x114.3 6.625x4.500	300 2.07		198	247	128	157	114
				7.795	9.724	5.039	6.181	4.488
200x25 8x1	219.1x33.7 8.625x1.327	300 2.07		250	310	152	77	46
				9.843	12.205	5.984	3.031	1.811
200x32 8x1 1/4	219.1x42.4 8.625x1.669	300 2.07		250	310	152	83	46
				9.843	12.205	5.984	3.268	1.811
200x40 8x1 1/2	219.1x48.3 8.625x1.900	300 2.07		250	310	152	92	51
				9.843	12.205	5.984	3.622	2.008
200x50 8x2	219.1x60.3 8.625x2.375	300 2.07		250	310	152	97	61
				9.843	12.205	5.984	3.819	2.402
200x65 8x2 1/2	219.1x73 8.625x2.874	300 2.07		250	310	152	116	70
				9.843	12.204	5.984	4.566	2.756
200x65 8x2 1/2	219.1x76.1 8.625x2.996	300 2.07		250	310	152	130	81
				9.843	12.205	5.984	5.118	3.189
200x80 8x3	219.1x88.9 8.625x3.500	300 2.07	2-M16x100	250	310	152	137	86
				9.843	12.205	5.984	5.394	3.386
200x100 8x4	219.1x114.3 8.625x4.500	300 2.07		250	310	152	162	114
				9.843	12.205	5.984	6.378	4.488
200x150 8x6	219.1x168.3 8.625x6.625	300 2.07		250	310	174	214	160
				9.843	12.205	6.850	8.425	6.299
250x100 10x4	273.0x114.3 10.748x4.500	300 2.07	2-M22x130	309	376	186	162	114
				12.165	14.803	7.323	6.378	4.488
250x125 10x6	273.0x139.7 10.748x5.500	300 2.07		309	376	186	186	135
				12.165	14.803	7.323	7.323	5.315



Mechanical Tee Threaded - GJMT16T

- Mechanical tees are fast and simple way to provide a grooved connection along the length of the pipe.
- It provides quick and economic connection of smaller branch pipes with cross mains or riser pipes.
- After a hole is drilled in the pipe where in the connection area, just connect the clamps around the pipe for a grooved connection.
- The mechanical tee eliminates the need for welding and the use of multiple fittings.
- Mechanical Tee housings are made of Ductile Iron confirming to ASTM A536 and the rubber gaskets are made by EPDM with rated working pressure up to 500 psi.
- Available with hot dipped galvanised coating as optional

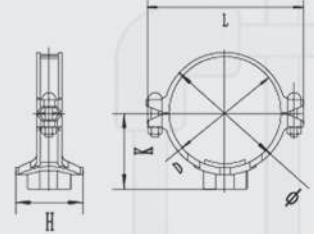

Normal Size mm/in	Pipe O,D mm/in	Working Pressure PSI/MPa	U-Bolt Size No-Size mm	Dimensions mm/in				Hole cutting dimensions mm/in
				O	L	K	H	
40x25 1 1/2 x 1	48.3x33.7 1.900x1.327	300 2.07	2-M10x45	67	112	56	61	32 1.259
				2.637	4.409	2.204	2.401	
				75	116	57	69	
				2.953	4.567	2.362	2.717	
				75	116	57	69	
				2.953	4.567	2.362	2.717	
50x15 2 x 1/2	60.3x21.3 2.375x0.839	300 2.07	2-M10x45	75	116	57	69	
				2.953	4.567	2.362	2.717	
				75	116	57	69	
				2.953	4.567	2.362	2.717	
				75	116	57	69	
				2.953	4.567	2.362	2.717	
50x20 2 x 3/4	60.3x26.9 2.375x1.059	300 2.07	2-M10x45	75	116	57	69	
				2.953	4.567	2.362	2.717	
				75	116	57	69	
				2.953	4.567	2.362	2.717	
				75	116	57	69	
				2.953	4.567	2.362	2.717	
50x25 2 x 1	60.3x33.7 2.375x1.327	300 2.07	2-M10x45	75	116	60	69	
				2.953	4.567	2.362	2.717	
				75	116	60	69	
				2.953	4.567	2.362	2.717	
				75	116	60	69	
				2.953	4.567	2.362	2.717	
50x32 2 x 1 1/4	60.3x42.4 2.375x1.669	300 2.07	2-M10x45	75	116	60	69	
				2.953	4.567	2.362	2.717	
				75	116	60	69	
				2.953	4.567	2.362	2.717	
				75	116	60	69	
				2.953	4.567	2.362	2.717	
50x40 2 x 1 1/2	60.3x48.3 2.375x1.900	300 2.07	2-M10x45	75	116	60	69	
				2.953	4.567	2.362	2.717	
				75	116	60	69	
				2.953	4.567	2.362	2.717	
				75	116	60	69	
				2.953	4.567	2.362	2.717	
65x25 2 1/2 x 1	73x33.7 2.874x1.327	300 2.07	2-M10x55	93	136	62	77	
				3.661	5.354	2.441	3.031	
				93	136	62	77	
				3.661	5.354	2.441	3.031	
				93	136	62	77	
				3.661	5.354	2.441	3.031	
65x32 2 1/2 x 1 1/4	73x42.4 2.874x1.669	300 2.07	2-M10x55	93	144	65	84	
				3.661	5.669	2.559	3.307	
				93	144	65	84	
				3.661	5.669	2.559	3.307	
				93	144	65	84	
				3.661	5.669	2.559	3.307	
65x40 2 1/2 x 1 1/2	73x48.3 2.874x1.901	300 2.07	2-M10x55	93	144	65	84	
				3.661	5.669	2.559	3.307	
				93	144	65	84	
				3.661	5.669	2.559	3.307	
				93	144	65	84	
				3.661	5.669	2.559	3.307	
65x50 2 1/2 x 2	73x60.3 2.874x2.375	300 2.07	2-M10x55	93	136	78	85	
				3.661	5.354	3.071	3.346	
				93	136	78	85	
				3.661	5.354	3.071	3.346	
				93	136	78	85	
				3.661	5.354	3.071	3.346	
65x20 2 1/2 x 3/4	76.1x26.9 2.996x1.059	300 2.07	2-M12x60	102	144	67	77	
				4.016	5.669	2.637	3.031	
				102	144	67	77	
				4.016	5.669	2.637	3.031	
				102	144	67	77	
				4.016	5.669	2.637	3.031	
65x25 2 1/2 x 1	76.1x33.7 2.996x1.327	300 2.07	2-M12x60	102	144	70	77	
				4.016	5.669	2.756	3.301	
				102	144	70	77	
				4.016	5.669	2.756	3.301	
				102	144	70	77	
				4.016	5.669	2.756	3.301	
65x32 2 1/2 x 1 1/4	76.1x42.4 2.996x1.669	300 2.07	2-M12x60	102	144	70	83	
				4.016	5.669	2.756	3.268	
				102	144	70	83	
				4.016	5.669	2.756	3.268	
				102	144	70	83	
				4.016	5.669	2.756	3.268	
65x40 2 1/2 x 1 1/2	76.1x48.3 2.996x1.900	300 2.07	2-M12x60	102	144	70	83	
				4.016	5.669	2.756	3.268	
				102	144	70	83	
				4.016	5.669	2.756	3.268	
				102	144	70	83	
				4.016	5.669	2.756	3.268	
65x40 2 1/2 x 2	76.1x60.3 2.996x2.375	300 2.07	2-M12x60	102	144	74	83	
				4.016	5.669	2.913	3.268	
				102	144	74	83	
				4.016	5.669	2.913	3.268	
				102	144	74	83	
				4.016	5.669	2.913	3.268	
80x15 3 x 1/2	88.9x21.3 3.600x0.839	300 2.07	2-M12x60	102	152	73	77	
				4.016	5.984	2.874	3.031	
				102	152	73	77	
				4.016	5.984	2.874	3.031	
				102	152	73	77	
				4.016	5.984	2.874	3.031	
80x20 3 x 3/4	88.9x26.9 3.500x1.059	300 2.07	2-M12x60	102	152	73	77	
				4.016	5.984	2.874	3.031	
				102	152	73	77	
				4.016	5.984	2.874	3.031	
				102	152	73	77	
				4.016	5.984	2.874	3.031	
80x25 3 x 1	88.9x33.7 3.500x1.327	300 2.07	2-M12x60	114	152	82	77	
				4.488	5.984	3.228	3.031	
				114	152	82	77	
				4.488	5.984	3.228	3.031	
				114	152	82	77	
				4.488	5.984	3.228	3.031	
80x32 3 x 1 1/4	88.9x42.4 3.500x1.669	300 2.07	2-M12x60	114	152	82	83	
				4.488	5.984	3.228	3.268	
				114	152	82	83	
				4.488	5.984	3.228	3.268	
				114	152	82	83	
				4.488	5.984	3.228	3.268	
80x40 3 x 1 1/2	88.9x48.3 3.500x1.900	300 2.07	2-M12x60	114	152	82	92	
				4.488	5.984	3.228	3.622	
				114	152	82	92	
				4.488	5.984	3.228	3.622	
				114	152	82	92	
				4.488	5.984	3.228	3.622	
80x50 3 x 2	88.9x60.3 3.500x2.375	300 2.07	2-M12x60	114	152	82	99	
				4.488	5.984	3.228	3.898	
				114	152	82	99	
				4.488	5.984	3.228	3.898	
				114	152	82	99	
				4.488	5.984	3.228	3.898	
100x25 4 x 1	108.0x33.7 4.252x1.327	300 2.07	2-M12x65	135	172	87	77	
				5.315	6.772	3.425	3.031	
				135	172	87	77	
				5.315	6.772	3.425	3.031	
				135	172	87	77	
				5.315	6.772	3.425	3.031	
100x32 4 x 1 1/4	108.0x42.4 4.252x1.669	300 2.07	2-M12x65	135	172	87	83	
				5.315	6.772	3.425	3.268	
				135	172	87	83	
				5.315	6.772	3.425	3.268	
				135	172	87	83	
				5.315	6.772	3.425	3.268	
100x40 4 x 1 1/2	108.0x48.3 4.252x1.900	300 2.07	2-M12x65	135	172	87	92	
				5.315	6.772	3.425	3.622	
				135	172	87	92	
				5.315	6.772	3.425	3.622	
				135	172	87	92	
				5.315	6.772	3.425	3.622	
100x50 4 x 2	108.0x60.3 4.252x2.375	300 2.07	2-M12x65	135	172	87	97	
				5.315	6.772	3.425	3.622	
				135	172	87	97	
				5.315	6.772	3.425	3.622	
				135	172	87	97	
				5.315	6.772	3.425	3.622	
100x65 4 x 2 1/2	108.0x76.1 4.252x2.996	300 2.07	2-M12x65	135	172	87	112	
				5.315	6.772	3.425	4.409	
				135	172	87	112	
				5.315	6.772	3.425	4.409	
				135	172	87	112	
				5.315	6.772	3.425	4.409	
100x80 4 x 3	114.3x88.9 4.500x3.500	300 2.07	2-M12x65	140	188	93	125	
				5.512	7.402	3.661	4.921	
				140	188	93	125	
				5.512	7.402	3.661	4.921	
				140	188	93	125	
				5.512	7.402	3.661	4.921	
125x25 5 x 1	133.0x33.7 5.236x1.327	300 2.07	2-M16x75	160	210	100	77	
				6.299	8.268	3.937	3.031	
				160	210	100	77	
				6.299	8.268	3.937	3.031	
				160	210	100	77	
				6.299	8.268	3.937	3.031	
125x32 5 x 1 1/4	133.0x42.4 5.236x1.669	300 2.07	2-M16x75	160	210	100	83	
				6.299	8.268	3.937	3.268	
				160	210	100	83	
				6.299	8.268	3.937	3.268	
				160	210	100	83	
				6.299	8.268	3.937	3.268	
125x40 5 x 1 1/2	133.0x48.3 5.236x1.900	300 2.07	2-M16x75	160	210	100	92	
				6.299	8.268	3.937	3.622	
				160	210	100	92	
				6.299	8.268	3.937	3.622	
				160	210	100	92	
				6.299	8.268	3.937	3.622	
125x50 5 x 2	133.0x60.3 5.236x2.375	300 2.07	2-M16x75	160	210	100	97	
				6.299	8.268	3.937	3.819	
				160	210	100	97	
				6.299	8.268	3.937	3.819	
				160	210	100	97	
				6.299	8.268	3.937	3.819	
125x65 5 x 2 1/2	133.0x76.1 5.236x2.996	300 2.07	2-M16x75	160	210	100	123	
				6.299	8.268	3.937	4.843	
				160	210	100	123	
				6.299	8.268	3.937	4.843	
				160	210	100	123	
				6.299	8.268	3.937	4.843	
125x25 5 x 1	139.7x33.7 5.500x1.327	300 2.07	2-M16x75	168	220	100	77	
				6.614	8.661	3.937	3.031	
				168	220	100	77	
				6.614	8.661	3.937	3.031	
				168	220	100	77	
				6.614	8.661	3.937	3.031	

Mechanical Tee Threaded - GJMT16T



- Mechanical tees are fast and simple way to provide a grooved connection along the length of the pipe.
- It provides quick and economic connection of smaller branch pipes with cross mains or riser pipes.
- After a hole is drilled in the pipe where in the connection area, just connect the clamps around the pipe for a grooved connection.
- The mechanical tee eliminates the need for welding and the use of multiple fittings.
- Mechanical Tee housings are made of Ductile Iron conforming to ASTM A536 and the rubber gaskets are made by EPDM with rated working pressure up to 500 psi.
- Available with hot dipped galvanised coating as optional

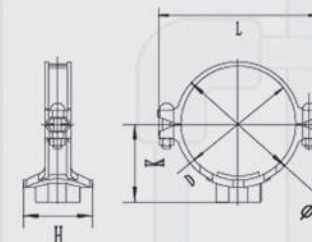

Normal Size mm/in	Pipe O.D mm/in	Working Pressure PSI/MPa	U-Bolt Size No-Size mm	Dimensions mm/in				Hole cutting dimensions mm/in	
				O	L	K	H		
125x32 5x1¼	139.7x42.4 5.500x1.669	300 2.07	2-M16x75	168 6.614	220 8.661	100 3.937	83 3.268	46 1.811	
125x40 5x1½	139.7x48.3 5.500x1.900	300 2.07		168 6.614	220 8.661	100 3.937	92 3.622	51 2.008	
125x50 5x2	139.7x60.3 5.500x2.375	300 2.07		168 6.614	220 8.661	107 4.213	97 3.819	61 2.402	
125x65 5x2½	139.7x76.1 5.500x2.996	300 2.07		168 6.614	220 8.661	107 4.213	123 4.843	81 3.189	
125x80 5x3	139.7x88.9 5.500x3.500	300 2.07		168 6.614	220 8.661	107 4.213	136 5.354	86 3.386	
150x25 6x1	159.0x33.7 6.260x1.327	300 2.07		187 7.362	242 9.528	117 4.606	77 3.031	38 1.496	
150x32 6x1¼	159.0x42.4 6.260x1.669	300 2.07		187 7.362	242 9.528	117 4.606	83 3.268	46 1.811	
150x40 6x1½	159.0x48.3 6.260x1.900	300 2.07		187 7.362	242 9.528	117 4.606	92 3.622	51 2.008	
150x50 6x2	159.0x60.3 6.260x2.375	300 2.07		187 7.362	242 9.528	117 4.606	97 3.819	61 2.402	
150x65 6x2½	159.0x76.1 6.260x2.996	300 2.07		187 7.362	242 9.528	117 4.606	123 4.848	81 3.189	
150x80 6x3	159.0x88.9 6.260x3.500	300 2.07		187 7.362	242 9.528	117 4.606	136 5.354	86 3.386	
150x25 6x1	165.1x33.7 6.500x1.327	300 2.07		2-M16x75	194 7.638	247 9.724	112 4.409	77 3.031	38 1.496
150x32 6x1¼	165.1x42.4 6.500x1.669	300 2.07	194 7.638		247 9.724	112 4.409	83 3.268	46 1.811	
150x40 6x1½	165.1x48.3 6.500x1.900	300 2.07	194 7.638		247 9.724	112 4.409	92 3.622	51 2.008	
150x50 6x2	165.1x60.3 6.500x2.375	300 2.07	194 7.638		247 9.724	116 4.567	97 3.819	61 2.402	
150x65 6x2½	165.1x76.1 6.500x2.996	300 2.07	194 7.638		247 9.724	125 4.921	123 4.843	81 3.189	
150x80 6x3	165.1x88.9 6.500x3.500	300 2.07	194 7.638		247 9.724	125 4.921	136 5.354	86 3.386	
150x100 6x4	165.1x114.3 6.500x4.500	300 2.07	194 7.638		247 9.724	125 4.921	156 6.142	114 4.488	
150x25 6x1	168.3x33.7 6.625x1.327	300 2.07	198 7.795		247 9.724	120 4.724	77 3.031	38 1.496	
150x32 6x1¼	168.3x42.4 6.625x1.669	300 2.07	198 7.795		247 9.724	120 4.724	82 3.228	46 1.811	
150x40 6x1½	168.3x48.3 6.625x1.900	300 2.07	198 7.795		247 9.724	120 4.724	92 3.622	51 2.007	
150x50 6x2	168.3x60.3 6.625x2.375	300 2.07	198 7.795		247 9.724	120 4.724	98 3.858	61 2.401	
150x65 6x2½	168.3x76.1 6.625x2.996	300 2.07	198 7.795		247 9.724	120 4.724	123 4.843	81 3.189	
150x80 6x3	168.3x88.9 6.625x3.500	300 2.07	198 7.795	247 9.724	120 4.724	136 5.354	86 3.386		
200x25 8x1	219.1x33.7 8.625x1.327	300 2.07	2-M16x85	250 9.843	310 12.205	146 5.748	77 3.031	46 1.811	
200x32 8x1¼	219.1x42.4 8.625x1.669	300 2.07		250 9.843	310 12.205	146 5.748	83 3.268	46 1.811	
200x40 8x1½	219.1x48.3 8.625x1.900	300 2.07		250 9.843	310 12.205	146 5.748	92 3.622	51 2.008	
200x50 8x2	219.1x60.3 8.625x2.375	300 2.07		250 9.843	310 12.205	146 5.748	97 3.819	61 2.402	
200x65 8x2½	219.1x76.1 8.625x2.996	300 2.07		250 9.843	310 12.205	146 5.748	130 5.118	81 3.189	
200x80 8x3	219.1x88.9 8.625x3.600	300 2.07		250 9.843	310 12.205	146 5.748	137 5.394	86 3.386	
200x100 8x4	219.1x114.3 8.625x4.500	300 2.07		250 9.843	310 12.205	146 5.748	162 6.378	114 4.488	
250x40 10x1¼	273.0x48.3 10.748x1.900	300 2.07		2-M16x100	309 9.843	376 12.205	174 5.748	92 3.622	51 2.008
250x50 10x2	273.0x60.3 10.748x2.375	300 2.07			309 9.843	376 12.205	174 5.748	97 3.819	61 2.402
250x65 10x2½	273.0x76.1 10.748x2.996	300 2.07			309 9.843	376 12.205	174 5.748	130 5.118	81 3.189
250x80 10x3	273.0x88.9 10.748x3.600	300 2.07			309 9.843	376 12.205	174 5.748	137 5.394	86 3.386
250x100 10x4	273.0x114.3 10.748x4.500	300 2.07			309 9.843	376 12.205	174 5.748	162 6.378	114 4.488



- Grooved Concentric Reducer designed for short center to end dimensions. It helps in easier installation.
- They are primarily used for fire protection applications and other related grooved piping system, can also be used for general services.
- The Concentric Reducer housings are made up of Ductile Iron conforming to ASTM A536 and the grooving standards AWWA C606 with maximum working pressure 500 psi.
- Available with hot dipped galvanised coating as optional

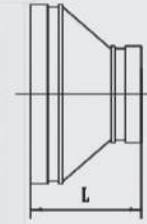

Normal Size mm/in	Pipe O.D mm/in	Working Pressure PSI/MPa	Dimension L mm/in
32x25	42.4x33.7	400	64
1½x1	1.669x1.327	2.75	2.52
40x25	48.3x33.7	400	64
1½x1	1.900x1.327	2.75	2.52
40x32	48.3x42.4	400	64
1½x1½	1.900x1.669	2.75	2.52
50x25	60.3x33.7	400	64
2x1	2.375x1.327	2.75	2.52
50x32	60.3x42.4	400	64
2x1½	2.375x1.669	2.75	2.52
50x40	60.3x48.3	400	64
2x1½	2.375x1.900	2.75	2.52
65x25	73x33.7	400	64
2½x1	2.87x1.327	2.75	2.52
65x32	73x42.4	400	64
2½x1½	2.87x1.669	2.75	2.52
65x40	73x48.3	400	64
2½x1½	2.87x1.900	2.75	2.52
65x50	73x60.3	400	64
2½x2	2.87x2.375	2.75	2.52
65x25	76.1x33.7	400	64
2½x1	2.996x1.327	2.75	2.52
65x32	76.1x42.4	400	64
2½x1½	2.996x1.669	2.75	2.52
65x40	76.1x48.3	400	64
2½x1½	2.996x1.900	2.75	2.52
65x50	76.1x60.3	400	64
2½x2	2.996x2.375	2.75	2.52
80x32	88.9x42.4	400	64
3x1½	3.500x1.669	2.75	2.52
80x40	88.9x48.3	400	64
3x1½	3.500x1.900	2.75	2.52
80x50	88.9x60.3	400	64
3x2	3.500x2.375	2.75	2.52
80x65	88.9x73.0	400	64
3x2½	3.500x2.875	2.75	2.52
80x65	88.9x76.1	400	64
3x2½	3.500x3.000	2.75	2.52
100x50	114.3x60.3	400	76
4x2	4.500x2.375	2.75	3.00
100x65	114.3x73.0	400	76
4x2½	4.500x2.875	2.75	3.00
100x65	114.3x76.1	400	76
4x2½	4.500x3.000	2.75	3.00
100x80	114.3x88.9	400	76
4x3	4.500x3.500	2.75	3.00
125x50	139.7x60.3	300	89
5x2	5.500x2.375	2.07	3.50
125x65	139.7x76.1	300	89
5x2½	5.500x3.000	2.07	3.50

Grooved Concentric Reducer - GJCR40G



- Grooved Concentric Reducer designed for short center to end dimensions. It helps in easier installation.
- They are primarily used for fire protection applications and other related grooved piping system, can also be used for general services.
- The Concentric Reducer housings are made up of Ductile Iron conforming to ASTM A536 and the grooving standards AWWA C606 with maximum working pressure 500 psi.
- Available with hot dipped galvanised coating as optional

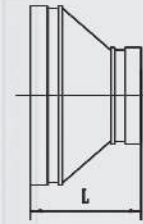

Normal Size mm/in	Pipe O.D mm/in	Working Pressure PSI/MPa	Dimension L mm/in
125x80	139.7x88.9	300	89
5x3	5.500x3.500	2.07	3.50
125x100	139.7x114.3	300	89
5x4	5.500x4.500	2.07	3.50
150x50	165.1x60.3	300	102
6x2	6.500x2.375	2.07	4.02
150x65	165.1x76.1	300	102
6x2½	6.500x3.000	2.07	4.02
150x80	165.1x88.9	300	102
6x3	6.500x3.500	2.07	4.02
150x100	165.1x114.3	300	102
6x4	6.500x4.500	2.07	4.02
150x125	165.1x139.7	300	102
6x5	6.500x5.500	2.07	4.02
150x50	168.3x60.3	300	102
6x2	6.625x2.375	2.07	4.02
150x65	168.3x73	300	102
6x2½	6.625x2.875	2.07	4.02
150x65	168.3x76.1	300	102
6x2½	6.625x3.000	2.07	4.02
150x80	168.3x88.9	300	102
6x3	6.625x3.500	2.07	4.02
150x100	168.3x114.3	300	102
6x4	6.625x4.500	2.07	4.02
150x125	168.3x139.7	300	102
6x5	6.625x5.500	2.07	4.02
200x150	216.3x165.1	300	127
8x6	8.625x6.500	2.07	5.00
200x50	219.1x60.3	300	127
8x2	8.625x2.375	2.07	5.00
200x65	219.1x73	300	127
8x2½	8.625x2.875	2.07	5.00
200x65	219.1x76.1	300	127
8x2½	8.625x3.000	2.07	5.00
200x80	219.1x88.9	300	127
8x3	8.625x3.500	2.07	5.00
200x100	219.1x114.3	300	127
8x4	8.625x4.500	2.07	5.00
200x125	219.1x139.7	300	127
8x5	8.625x5.500	2.07	5.00
200x150	219.1x165.1	300	127
8x6	8.625x6.500	2.07	5.00
200x150	219.1x168.3	300	127
8x6	8.625x6.625	2.07	5.00
250x100	273.0x114.3	300	152
10x4	10.75x4.500	2.07	5.98
250x150	273.0x165.1	300	152
10x6	10.75x6.500	2.07	5.98
250x150	273.0x168.3	300	152
10x6	10.75x6.625	2.07	5.98
250x200	273.0x219.1	300	152
10x8	10.75x8.625	2.07	5.98
300x150	323.9x165.1	300	178
12x6	12.75x6.500	2.07	7.00
300x150	323.9x168.3	300	178
12x6	12.75x6.500	2.07	7.00
300x200	323.9x219.1	300	178
12x8	12.75x8.625	2.07	7.00
300x250	323.9x273	300	178
12x10	12.75x10.75	2.07	7.00



Grooved Concentric Reducer Threaded Ends - GJCR40T

- Grooved Concentric Reducer designed for short center to end dimensions. It helps in easier installation.
- They are primarily used for fire protection applications and other related grooved piping system, can also be used for general services.
- The Concentric Reducer housings are made up of Ductile Iron conforming to ASTM A536 and the grooving standards AWWA C606 with maximum working pressure 500 psi.
- Available with hot dipped galvanised coating as optional

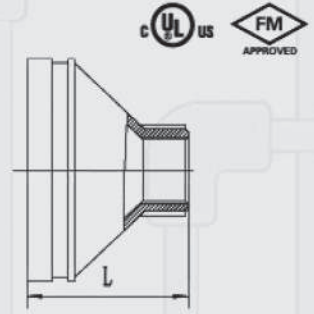

Normal size mm/in	Pipe O.D mm/in	Working Pressure PSI/MPa	Dimension L mm/in
40x25 1½x1	48.3x33.7 1.900x1.327	400 2.75	64 2.52
50x25 2x1	60.3x33.7 2.375x1.327	400 2.75	64 2.52
50x32 2x1¼	60.3x42.4 2.375x1.669	400 2.75	64 2.52
50x40 2x1½	60.3x46.3 2.375x1.900	400 2.75	64 2.52
65x25 2½x1	73x33.7 2.87x1.327	400 2.75	64 2.52
65x32 2½x1	73x42.4 2.87x1.669	400 2.75	64 2.52
65x40 2½x1	76.1x48.3 2.996x1.669	400 2.75	64 2.52
65x50 2½x1	73x60.3 2.87x2.375	400 2.75	64 2.52
65x25 2½x1	76.1x33.7 2.996x1.327	400 2.75	64 2.52
65x32 2½x1	76.1x42.4 2.996x1.669	400 2.75	64 2.52
65x40 2½x1	76.1x48.3 2.996x1.669	400 2.75	64 2.52
65x50 2½x1	76.1x60.3 2.996x2.375	400 2.75	64 2.52
80x25 3x1	88.9x33.7 3.500x1.327	400 2.75	64 2.52
80x32 3x1¼	88.9x42.4 3.500x1.669	400 2.75	64 2.52
80x40 3x1½	88.9x48.3 3.500x1.900	400 2.75	64 2.52
80x50 3x2	88.9x60.3 3.500x2.375	400 2.75	64 2.52
80x65 3x2½	88.9x73.0 3.500x2.875	400 2.75	64 2.52
80x65 3x2½	88.9x76.1 3.500x3.000	400 2.75	64 2.52
100x25 4x1	114.3x33.7 4.500x1.327	400 2.75	76 3.00
100x32 4x1¼	114.3x42.4 4.500x1.669	400 2.75	76 3.00
100x40 4x1½	114.3x48.3 4.500x1.900	400 2.75	76 3.00
100x50 4x2	114.3x60.3 4.500x2.375	400 2.75	76 3.00
100x65 4x2½	114.3x73.0 4.500x2.875	400 2.75	76 3.00
100x65 4x2½	114.3x76.1 4.500x3.000	400 2.75	76 3.00
100x80 4x3	114.3x88.9 4.500x3.500	400 2.75	76 3.00
125x25 5x1	139.7x33.7 5.500x1.327	300 2.07	89 3.50

Grooved Concentric Reducer Threaded Ends - GJCR40T



- Grooved Concentric Reducer designed for short center to end dimensions. It helps in easier installation.
- They are primarily used for fire protection applications and other related grooved piping system, can also be used for general services.
- The Concentric Reducer housings are made up of Ductile Iron conforming to ASTM A536 and the grooving standards AWWA C606 with maximum working pressure 500 psi.
- Available with hot dipped galvanised coating as optional

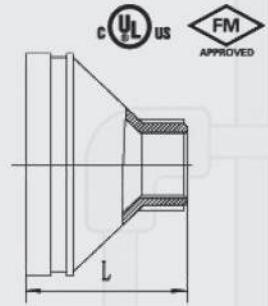

Normal size mm/in	Pipe O.D mm/in	Working Pressure PSI/MPa	Dimension L mm/in
125x32 5x1¼	139.7x42.4 5.500x1.669	300 2.07	89 3.50
125x40 5x1½	139.7x48.3 5.500x1.900	300 2.07	89 3.50
125x50 5x2	139.7x60.3 5.500x2.375	300 2.07	89 3.50
125x65 5x2½	139.7x76.1 5.500x3.000	300 2.07	89 3.50
125x80 5x3	139.7x88.9 5.500x3.500	300 2.07	89 3.50
125x100 5x4	139.7x114.3 5.500x4.500	300 2.07	89 3.50
150x25 6x1	165.1x33.7 6.500x1.327	300 2.07	102 4.02
150x32 6x1¼	165.1x42.4 6.500x1.669	300 2.07	102 4.02
150x40 6x1½	165.1x48.3 6.500x1.900	300 2.07	102 4.02
150x50 6x2	165.1x60.3 6.500x2.375	300 2.07	102 4.02
150x65 6x2½	165.1x76.1 6.500x3.000	300 2.07	102 4.02
150x80 6x3	165.1x88.9 6.500x3.500	300 2.07	102 4.02
150x100 6x4	165.1x114.3 6.500x4.500	300 2.07	102 4.02
150x25 6x1	168.3x33.7 6.625x1.327	300 2.07	102 4.02
150x50 6x2	168.3x60.3 6.625x2.375	300 2.07	102 4.02
150x65 6x2½	168.3x76.1 6.625x3.000	300 2.07	102 4.02
150x80 6x3	168.3x88.9 6.625x3.500	300 2.07	102 4.02
200x50 8x2	219.1x60.3 8.625x2.375	300 2.07	127 5.00
200x65 8x2½	219.1x76.1 8.625x3.000	300 2.07	127 5.00
200x80 8x3	219.1x88.9 8.625x3.500	300 2.07	127 5.00

- Grovjoint reducer tee are designed to join different diameter pipes which are perpendicular to the direction of flow.
- They provide minimum pressure drop. They are primarily designed for fire protection applications and other related grooved piping system. It can also be used for general services.
- Grooved Reducing tee housings are made up of Ductile Iron confirming to ASTM A536 and the grooving standards AWWA C606 with rated working pressure up to 500 psi.
- The grooved reducing tee features short center to end dimensions and it helps easier installation in less space.
- Available with hot dipped galvanised coating as optional

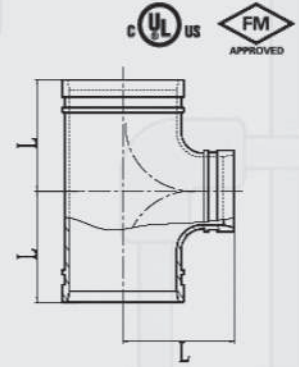

Size DN Inch	Pipe O.D mm/in	Working Pressure PSI/MPa	Dimension L mm/in
40x32	48.3x48.3x42.4	400	60
1½x1¼	1.900x1.900x1.660	2.75	2.362
50x32	60.3x60.3x42.4	400	70
2x1¼	2.375x2.375x1.600	2.75	2.755
50x40	60.3x60.3x48.3	400	70
2x1½	2.375x2.375x1.900	2.75	2.755
65x25	73.0x73.0x33.7	400	76
2½x1	2.875x2.875x1.315	2.75	2.992
65x32	73.0x73.0x42.4	400	76
2½x1¼	2.875x2.875x1.660	2.75	2.992
65x40	73.0x73.0x48.3	400	76
2½x1½	2.875x2.875x1.900	2.75	2.992
65x50	73.0x73.0x60.3	400	76
2½x2	2.875x2.875x2.375	2.75	2.992
65x25	76.1x76.1x33.7	400	76
2½x1	3.000x3.000x1.315	2.75	2.992
65x32	76.1x76.1x42.4	400	76
2½x1¼	3.000x3.000x1.660	2.75	2.992
65x40	76.1x76.1x48.3	400	76
2½x1½	3.000x3.000x1.900	2.75	2.992
65x50	76.1x76.1x60.3	232	76
2½x2	3.000x3.000x2.375	1.6	2.992
80x25	88.9x88.9x33.7	400	86
3x1	3.500x3.500x1.315	2.75	3.386
80x32	88.9x88.9x42.4	400	86
3x1¼	3.500x3.500x1.660	2.75	3.386
80x40	88.9x88.9x48.3	400	86
3x1½	3.500x3.500x1.900	2.75	3.386
80x50	88.9x88.9x60.3	400	86
3x2	3.500x3.500x2.375	2.75	3.386
80x65	88.9x88.9x73.0	400	86
3x2½	3.500x3.500x2.875	2.75	3.386
80x65	88.9x88.9x76.1	232	86
3x2½	3.500x3.500x3.000	1.6	3.386
100x50	114.3x114.3x60.3	400	101.5
4x2	4.500x4.500x2.375	2.75	3.996
100x65	114.3x114.3x73.0	400	101.5
4x2½	4.500x4.500x2.875	2.75	3.996
100x65	114.3x114.3x76.1	400	101.5
4x2½	4.500x4.500x3.000	2.75	3.996
100x80	114.3x114.3x88.9	400	101.5
4x3	4.500x4.500x3.500	2.75	3.996
125x50	139.7x139.7x60.3	300	122
5x2	5.500x5.500x2.375	2.07	4.803
125x65	139.7x139.7x76.1	300	122
5x2½	5.500x5.500x3.000	2.07	4.803
125x80	139.7x139.7x88.9	300	122
5x3	5.500x5.500x3.500	2.07	4.803
125x100	139.7x139.7x114.3	300	122
5x4	5.500x5.500x4.500	2.07	4.803
150x50	165.1x165.1x60.3	400	140
6x2	6.500x6.500x2.375	2.75	5.511



- Grovjoint reducer tee are designed to join different diameter pipes which are perpendicular to the direction of flow.
- They provide minimum pressure drop. They are primarily designed for fire protection applications and other related grooved piping system. It can also be used for general services.
- Grooved Reducing tee housings are made up of Ductile Iron conforming to ASTM A536 and the grooving standards AWWA C606 with rated working pressure up to 500 psi.
- The grooved reducing tee features short center to end dimensions and it helps easier installation in less space.
- Available with hot dipped galvanised coating as optional

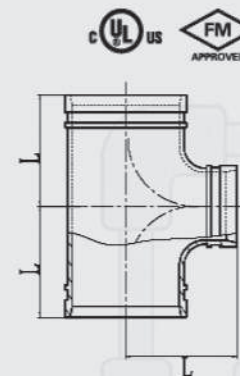

Size DN Inch	Pipe O.D mm/in	Working Pressure PSI/MPa	Dimension L mm/in
150x65 6x2½	165.1x165.1x76.3 6.500x6.500x3.000	400 2.75	140 5.511
150x80 6x3	165.1x165.1x88.9 6.500x6.500x3.500	400 2.75	140 5.511
150x100 6x4	165.1x165.1x114.3 6.500x6.500x4.500	400 2.75	140 5.511
150x40 6x1½	168.3x168.3x48.3 6.625x6.625x1.900	400 2.75	140 5.511
150x50 6x2	168.3x168.3x60.3 6.625x6.625x2.375	400 2.75	140 5.511
150x65 6x2½	168.3x168.3x73.0 6.625x6.625x2.875	400 2.75	140 5.511
150x65 6x2½	168.3x168.3x76.3 6.625x6.625x3.000	400 2.75	140 5.511
150x80 6x3	168.3x168.3x88.9 6.625x6.625x3.500	400 2.75	140 5.511
150x100 6x4	168.3x168.3x114.3 6.625x6.625x4.500	400 2.75	140 5.511
150x125 6x5	168.3x168.3x139.7 6.625x6.625x5.500	400 2.75	140 5.511
200x50 8x2	219.1x219.1x60.3 8.625x8.625x2.375	300 2.07	175 6.889
200x65 8x2½	219.1x219.1x73.0 8.625x8.625x2.875	300 2.07	175 6.889
200x65 8x2½	219.3x219.3x76.3 8.625x8.625x3.000	232 1.6	175 6.889
200x80 8x3	219.1x219.1x88.9 8.625x8.625x3.500	232 1.6	175 6.889
200x100 8x4	219.1x219.1x114.3 8.625x8.625x4.500	300 2.07	175 6.889
200x125 8x5	219.1x219.1x139.7 8.625x8.625x5.500	232 1.6	175 6.889
200x150 8x6	219.1x219.1x165.1 8.625x8.625x6.500	300 2.07	175 6.889
200x150 8x6	219.1x219.1x168.3 8.625x8.625x6.625	300 2.07	175 6.889
250x100 10x4	273.0x273.0x114.3 10.750x10.750x4.500	300 2.07	229 9.015
250x125 10x5	273.0x273.0x139.7 10.750x10.750x5.500	300 2.07	229 9.015
250x150 10x6	273.0x273.0x165.1 10.750x10.750x6.500	300 2.07	229 9.015
250x200 10x8	273.0x273.0x219.1 10.750x10.750x8.625	300 2.07	229 9.015
300x100 12x4	323.9x323.9x114.3 12.750x12.750x4.500	300 2.07	254 10
300x150 12x6	323.9x323.9x165.1 12.750x12.750x6.500	300 2.07	254 10
300x200 12x8	323.9x323.9x219.1 12.750x12.750x8.625	300 2.07	254 10
300x250 12x10	323.9x323.9x273.0 12.750x12.750x10.75	300 2.07	254 10
80x100 3x4	88.9x88.9x114.3 3.500x3.500x4.500	365 2.52	86 3.386
80x150 3x6	88.9x88.9x165.1 3.500x3.500x6.500	365 2.52	86 3.386
100x150 4x6	114.3x114.3x165.1 4.500x4.500x6.500	365 2.52	101.5 3.996

- Grovjoint reducer tee are designed to join different diameter pipes which are perpendicular to the direction of flow.
- They provide minimum pressure drop. They are primarily designed for fire protection applications and other related grooved piping system. It can also be used for general services.
- Grooved Reducing tee housings are made up of Ductile Iron conforming to ASTM A536 and the grooving standards AWWA C606 with rated working pressure up to 500 psi.
- The grooved reducing tee features short center to end dimensions and it helps easier installation in less space
- Available with hot dipped galvanised coating as optional

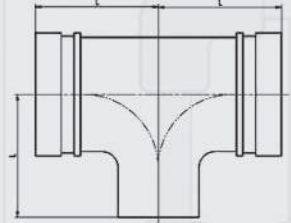

Normal Size mm/in	Pipe O.D mm/in	Working Pressure PSI/MPa	Dimension L mm/in
32x25 1½x1	42.4x42.4x33.7 1.660x1.600x1.315	232 1.6	60 2.362
40x25 1½x1	48.3x48.3x33.7 1.900x1.900x1.315	232 1.6	60 2.362
40x32 1½x1½	48.3x48.3x42.4 1.900x1.900x1.660	232 1.6	60 2.362
50x25 2x1	60.3x60.3x33.7 2.375x2.375x1.315	300 2.07	70 2.755
50x32 2x1½	60.3x60.3x42.4 2.375x2.375x1.660	300 2.07	70 2.755
50x40 2x1½	60.3x60.3x48.3 2.375x2.375x1.900	300 2.07	70 2.755
65x25 2½x1	73.0x73.0x33.7 2.875x2.875x1.315	400 2.75	76 2.992
65x32 2½x1½	73.0x73.0x42.4 2.875x2.875x1.660	400 2.75	76 2.992
65x40 2½x1½	73.0x73.0x48.3 2.875x2.875x1.900	400 2.75	76 2.992
65x50 2½x2	73.0x73.0x60.3 2.875x2.875x2.375	400 2.75	76 2.992
65x25 2½x1	76.1x76.1x33.7 3.000x3.000x1.315	300 2.07	76 2.992
65x32 2½x1½	76.1x76.1x42.4 3.000x3.000x1.660	300 2.07	76 2.992
65x40 2½x1½	76.1x76.1x48.3 3.000x3.000x1.900	300 2.07	76 2.992
65x50 2½x2	76.1x76.1x60.3 3.000x3.000x2.375	300 2.07	76 2.992
80x25 3x1	88.9x88.9x33.7 3.500x3.500x1.315	300 2.07	86 3.386
80x32 3x1½	88.9x88.9x42.4 3.500x3.500x1.660	300 2.07	86 3.386
80x40 3x1½	88.9x88.9x48.3 3.500x3.500x1.900	300 2.07	86 3.386
80x50 3x2	88.9x88.9x60.3 3.500x3.500x2.375	300 2.07	86 3.386
80x65 3x2½	88.9x88.9x76.1 3.500x3.500x3.000	232 1.6	86 3.386
100x25 4x1	114.3x114.3x33.7 4.500x4.500x1.315	300 2.07	101.5 3.996
100x32 4x1½	114.3x114.3x42.4 4.500x4.500x1.660	300 2.07	101.5 3.996



- Grovjoint reducer tee are designed to join different diameter pipes which are perpendicular to the direction of flow.
- They provide minimum pressure drop. They are primarily designed for fire protection applications and other related grooved piping system. It can also be used for general services.
- Grooved Reducing tee housings are made up of Ductile Iron conforming to ASTM A536 and the grooving standards AWWA C606 with rated working pressure up to 500 psi.
- The grooved reducing tee features short center to end dimensions and it helps easier installation in less space
- Available with hot dipped galvanised coating as optional

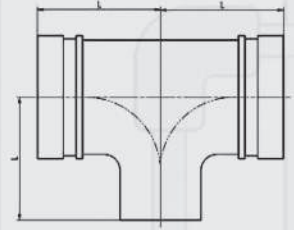

Normal Size mm/in	Pipe O.D mm/in	Working Pressure PSI/MPa	Dimension L mm/in
100x40 4x1½	114.3x114.3x48.3 4.500x4.500x1.900	300 2.07	101.5 3.996
100x50 4x2	114.3x114.3x60.3 4.500x4.500x2.375	300 2.07	101.5 3.996
100x65 4x2½	114.3x114.3x73.0 4.500x4.500x2.875	300 2.07	101.5 3.996
100x65 4x2½	114.3x114.3x76.1 4.500x4.500x3.000	300 2.07	101.5 3.996
100x80 4x3	114.3x114.3x88.9 4.500x4.500x3.500	300 2.07	101.5 3.996
125x25 5x1	139.7x139.7x33.7 5.500x5.500x1.315	300 2.07	122 4.803
125x32 5x1¼	139.7x139.7x42.4 5.500x5.500x1.660	300 2.07	122 4.803
125x40 5x1½	139.7x139.7x48.3 5.500x5.500x1.900	300 2.07	122 4.803
125x50 5x2	139.7x139.7x60.3 5.500x5.500x2.375	300 2.07	122 4.803
125x65 5x2½	139.7x139.7x76.1 5.500x5.500x3.000	300 2.07	122 4.803
125x80 5x3	139.7x139.7x88.9 5.500x5.500x3.500	300 2.07	122 4.803
150x25 6x1	165.1x165.1x33.7 6.500x6.500x1.315	300 2.07	140 5.511
150x32 6x1¼	165.1x165.1x42.4 6.500x6.500x1.660	300 2.07	140 5.511
150x40 6x1½	165.1x165.1x48.3 6.500x6.500x1.900	300 2.07	140 5.511
150x50 6x2	165.1x165.1x60.3 6.500x6.500x2.375	300 2.07	140 5.511
150x65 6x2½	165.1x165.1x76.3 6.500x6.500x3.000	300 2.07	140 5.511
150x80 6x3	165.1x165.1x88.9 6.500x6.500x3.500	300 2.07	140 5.511
150x100 6x4	165.1x165.1x114.3 6.500x6.500x4.500	300 2.07	140 5.511
150x32 6x1¼	168.3x168.3x42.4 6.625x6.625x1.660	300 2.07	140 5.511
150x40 6x1½	168.3x168.3x48.3 6.625x6.625x1.900	300 2.07	140 5.511
150x50 6x2	168.3x168.3x60.3 6.625x6.625x2.375	300 2.07	140 5.511
150x65 6x2½	168.3x168.3x76.3 6.625x6.625x3.000	300 2.07	140 5.511
150x80 6x3	168.3x168.3x88.9 6.625x6.625x3.500	300 2.07	140 5.511
200x80 8x3	219.1x219.1x88.9 8.625x8.625x3.500	300 2.07	175 6.889
200x100 8x4	219.1x219.1x114.3 8.625x8.625x4.500	300 2.07	175 6.889



- Grooved Eccentric Reducer designed for short center to end dimensions. It helps in easier installation.
- They are primarily used for fire protection applications and other related grooved piping system, can also be used for general services.
- The Eccentric Reducer housings are made up of Ductile Iron conforming to ASTM A536 and the grooving standards AWWA C606 with maximum working pressure 500 psi.
- Available with hot dipped galvanised coating as optional

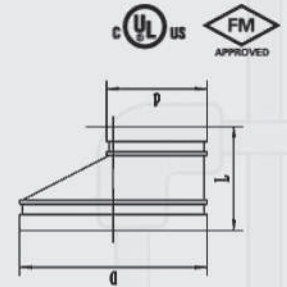

Normal Size mm/in	Pipe O.D Dimension mm/in	Working Pressure PSI/MPa	Dimension L mm/in
80x50	88.9x60.3	500	64
3x2	3.500x2.375	3.45	2.52
80x65	88.9x73.0	500	64
3x2½	3.500x2.875	3.45	2.52
80x65	88.9x76.1	500	64
3x2½	3.500x3.000	3.45	2.52
100x50	114.3x60.3	500	76
4x2	4.500x2.375	3.45	3.00
100x65	114.3x73.0	500	76
4x2½	4.500x2.875	3.45	3.00
100x65	114.3x76.1	500	76
4x2½	4.500x3.000	3.45	3.00
100x80	114.3x88.9	500	76
4x3	4.500x3.500	3.45	3.00
125x65	139.7x76.1	500	89
5x2½	5.500x3.000	3.45	3.50
125x80	139.7x88.9	500	89
5x3	5.500x3.500	3.45	3.50
125x100	139.7x114.3	500	89
5x4	5.500x4.500	3.45	3.50
150x50	159.0x60.3	500	102
6x2	6.250x2.375	3.45	4.02
150x65	159.0x76.1	500	102
6x2½	6.250x3.000	3.45	4.02
150x80	159.0x88.9	500	102
6x3	6.250x3.500	3.45	4.02
150x100	159.0x108.0	500	102
6x4	6.250x4.250	3.45	4.02
150x100	159.0x114.3	500	102
6x4	6.625x4.500	3.45	4.02
150x65	165.1x76.1	500	102
6x2½	6.500x3.000	3.45	4.02
150x80	165.1x88.9	500	102
6x3	6.500x3.500	3.45	4.02
150x100	165.1x114.3	500	102
6x4	6.500x4.500	3.45	4.02
150x125	165.1x139.7	500	102
6x5	6.500x5.500	3.45	4.02
150x80	168.3x88.9	500	102
6x3	6.625x3.500	3.45	4.02
150x100	168.3x114.3	500	102
6x4	6.625x4.500	3.45	4.02
150x125	168.3x139.7	500	102
6x5	6.625x5.500	3.45	4.02
200x80	219.1x88.9	500	127
8x3	8.625x3.500	3.45	5.00
500x100	219.1x114.3	500	127
8x4	8.625x4.500	3.45	5.00
200x125	219.1x139.7	500	127
8x5	8.625x5.500	3.45	5.00
200x150	219.1x165.1	500	127
8x6	8.625x6.500	3.45	5.00
200x150	219.1x168.3	500	127
8x6	8.625x6.625	3.45	5.00
250x150	273.0x165.1	500	152
10x6	10.75x6.500	3.45	5.98
250x150	273.0x168.3	500	152
10x6	10.75x6.625	3.45	5.98
250x200	273.0x219.1	500	152
10x8	10.75x8.625	3.45	5.98



Grooved Flange PN-16 (GJF14PN)

- Grooved flange provides a rigid transition to a grooved piping system without welding
- Flange body is made of Ductile Iron conforming to ASTM A536 and the rubber gaskets are made by EPDM with rated working pressure up to 300 psi.
- Available with hot dipped galvanised coating as optional

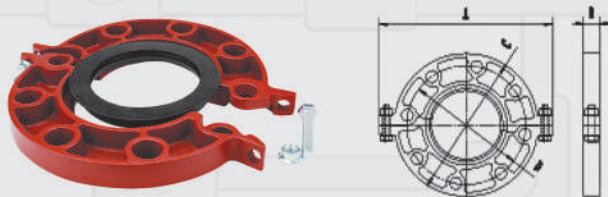

Normal Size mm/in	Pipe O.D mm/in Dimension	Working Pressure PSI/MPa	A mm/in	B mm/in	C mm/in	D mm/in	Bolt size No.-size mm
50 2	60.3 2.375	300 2.07	222 8.740	23 0.906	165 6.496	125 4.921	4-M10
65 2 1/2	73 2.875	300 2.07	240 9.448	23 0.906	185 7.283	145 5.708	4-M16
65 2 1/2	76.1 3.000	300 2.07	240 9.448	23 0.906	185 7.283	145 5.708	4-M16
80 3	88.9 3.500	300 2.07	252 9.921	23 0.906	192 7.559	160 6.299	8-M16
100 4	108 4.252	300 2.07	280 11.023	23 0.906	220 8.661	180 7.080	8-M16
100 4	114.3 4.500	300 2.07	280 11.023	23 0.906	220 8.661	180 7.086	8-M16
125 5	139.7 5.500	300 2.07	316 12.44	24 0.944	250 9.842	210 8.267	8-M16
125 5	141.3 5.563	300 2.07	324 12.75	24 0.944	250 9.842	210 8.267	8-M16
150 6	159 6.260	300 2.07	346 13.622	24 0.944	285 11.22	240 9.448	8-M16
150 6	168.3 6.625	300 2.07	346 13.622	24 0.944	285 11.22	240 9.448	8-M20
200 8	219.1 8.625	300 2.07	418 16.456	28 1.102	340 13.38	295 11.614	12-M20

Grooved Flange ANSI Class-150 (GJFL14A)

- Grooved flange provides a rigid transition to a grooved piping system from a flanged component.
- Flange body is made up of Ductile Iron conforming to ASTM A536 and the rubber gaskets are made by EPDM with rated working pressure up to 300 psi.
- Grooved flanges are supplied as per ANSI class 150 drilling pattern as standard.
- Available with hot dipped galvanised coating as optional



Normal Size mm/in	Pipe O.D mm/in Dimension	Working Pressure PSI/MPa	A mm/in	B mm/in	C mm/in	D mm/in	Bolt size No.-size mm
50 2	60.3 2.375	300 2.07	200 8.110	22 0.866	152 5.984	121 4.763	4-M16
65 2 1/2	73.0 2.875	300 2.07	230 9.055	22 0.866	178 7.007	140 5.511	4-M16
80 3	88.9 3.500	300 2.07	242 9.527	24 0.944	191 7.519	152 5.984	4-M16
100 4	114.3 4.500	300 2.07	280 11.023	24 0.944	229 9.015	191 7.519	8-M16
125 5	139.7 5.500	300 2.07	325 17.795	24.5 0.964	254 10	216 8.503	8-M20
125 5	141.3 5.563	300 2.07	325 12.795	24.5 0.964	254 10	216 8.503	8-M20
150 6	168.3 6.625	300 2.07	345 13.583	24.5 0.964	282 11.102	241.5 9.508	8-M20
200 8	219.1 8.625	300 2.07	414.3 16.311	28 1.102	341.4 13.44	298.5 11.751	8-M20

Grooved Flange Threaded PN-16 (GJFA19T)

- Threaded flange adaptor is designed to provide a rigid flanged component without welding
- Flange body is made of Ductile Iron conforming to ASTM A536 and threaded BSPT or NPT with rated working pressure up to 500 psi.
- Available with hot dipped galvanised coating as optional



Normal Size mm/in	Pipe O.D mm/in Dimension	Working Pressure PSI/MPa	Dimension mm/in				Bolt size No.-size mm
			L mm/in	X mm/in	Y mm/in	Z mm/in	
50 2	60.3 2.375	300 2.07	32 1.306	165 6.496	125 4.92	19 0.748	4-M16
65 2 1/2	76.1 3.000	300 2.07	32 1.306	185 7.283	145 5.70	19 0.748	4-M16
80 3	88.9 3.500	300 2.07	34 1.388	200 7.874	150 6.29	19 0.748	8-M16
100 4	114.3 4.500	300 2.07	40 1.633	220 8.661	180 7.08	19 0.748	8-M16



Grooved Flange Adapter PN-16 (GJFA19P)

- Flange body is made of Ductile Iron conforming to ASTM A536 with rated working pressure up to 500 psi.
- Available with hot dipped galvanised coating as optional

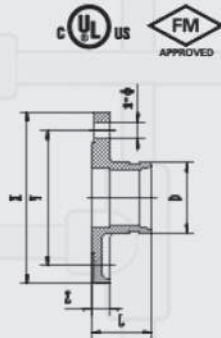

Normal Size mm/in	Pipe O.D mm/in Dimension	Working Pressure PSI/MPa	Dimension mm/in				Bolt size No.-size mm
			L mm/in	X mm/in	Y mm/in	Z mm/in	
50	60.3	300	60.3	165	125	19	4-M16
2	2.375	2.07	2.37	6.496	4.92	0.748	
65	73.0	300	60.3	185	145	19	4-M16
2 ½	2.875	2.07	2.37	7.283	5.70	0.748	
65	76.1	300	60.3	185	145	19	4-M16
2 ½	3.000	2.07	2.37	7.283	5.70	0.748	
80	88.9	300	60.3	200	160	19	8-M16
3	3.500	2.07	2.37	7.874	6.29	0.748	
100	108.0	300	70	220	180	19	8-M16
4	4.250	2.07	2.755	8.661	7.08	0.748	
100	114.3	300	70	220	180	19	8-M16
4	4.500	2.07	2.755	8.661	7.08	0.748	
125	133.0	300	60.3	250	210	19	8-M16
5	5.250	2.07	2.37	9.842	8.26	0.748	
125	139.7	300	60.3	250	210	19	8-M16
5	5.500	2.07	2.37	9.842	8.26	0.748	
125	141.3	300	70	250	210	19	8-M16
5	5.563	2.07	2.755	9.842	8.26	0.748	
150	159.0	300	70	285	240	19	8-M20
6	6.250	2.07	2.755	11.22	9.448	0.748	
150	165.1	300	70	285	240	19	8-M20
6	6.500	2.07	2.755	11.22	9.448	0.748	
150	168.3	300	70	285	240	19	8-M20
6	6.625	2.07	2.755	11.22	9.448	0.748	
200	219.1	300	76.1	340	295	20	12-M20
8	8.625	2.07	2.99	13.39	11.61	0.748	
250	273.0	300	85	405	355	22	12-M20
10	10.750	2.07	3.346	15.944	13.97	0.866	
300	323.9	300	90	460	410	24.5	12-M20
12	12.750	2.07	3.543	18.11	16.14	0.96	
350	377.0	300	100	520	470	24.5	16-M24
14	14.843	2.07	3.937	20.47	18.50	1.02	

Grooved Flange Adapter ANSI (Class-150) (GJFA19A)

- Flange body is made of Ductile Iron conforming to ASTM A536 with rated working pressure up to 500 psi.
- Available with hot dipped galvanised coating as optional

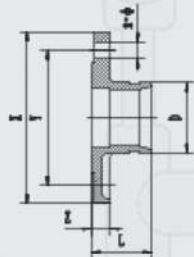

Normal Size mm/in	Pipe O.D mm/in Dimension	Working Pressure PSI/MPa	Dimension mm/in				Bolt size No.-size mm
			L mm/in	X mm/in	Y mm/in	Z mm/in	
50	60.3	300	65	152	120.5	16	4-M16
2	2.375	2.07	2.56	5.98	4.744	0.629	
65	73.0	300	65	178	139.5	17.5	4-M16
2 ½	2.875	2.07	2.56	7.00	5.693	0.688	
80	88.9	300	65	190	152.5	19	4-M16
3	3.500	2.07	2.56	7.48	6.00	0.748	
100	114.3	300	70	229	190.5	24	8-M16
4	4.500	2.07	2.755	9.015	7.5	0.96	
125	141.3	300	70	254	216	24	8-M20
5	5.562	2.07	2.755	10	8.503	0.96	
150	168.3	300	70	279	241.5	25.5	8-M20
6	6.625	2.07	2.755	10.98	9.507	1.10	
200	219.1	300	82	343	298.5	28.5	8-M20
8	8.625	2.07	3.228	13.50	11.751	1.112	
250	273.0	300	85	406	362	30	12-M24
10	10.750	2.07	3.346	15.98	14.251	1.181	
300	323.9	300	90	483	432	32	12-M24
12	12.750	2.07	3.543	19.01	17.00	1.259	

Grooved End Cap (GJCP55G)

- Grooved End Cap is designed to terminate grooved piping end for temporary or permanent basis.
- End Cap Body is made of Ductile Iron confirming to ASTM A536 and Grooving standards AWWA C606 with rated working pressure up to 500 psi.
- Available with hot dipped galvanised coating as optional



Size DN in	Pipe O.D mm/in Dimension	Working Pressure PSI/MPa	L mm/in
25	33.7	400	24.5
1	1.315	2.75	0.96
32	42.4	400	24.5
1¼	1.660	2.75	0.96
40	48.3	400	24.5
1½	1.900	2.75	0.96
50	60.3	400	24.5
2	2.375	2.75	0.96
65	73.0	400	24.5
2½	2.875	2.75	0.96
65	76.1	400	24.5
2½	3.000	2.75	0.96
80	88.9	400	24.5
3	3.500	2.75	0.96
100	108.0	400	25
4	4.252	2.75	0.99
100	114.3	300	25
4	4.500	2.07	0.99
125	133.0	300	25
5	5.250	2.07	0.99
125	139.7	300	25
5	5.500	2.07	0.99
150	159.0	300	25
6	6.260	2.07	0.99
150	165.1	300	25
6	6.500	2.07	0.99
150	168.3	300	25
6	6.625	2.07	0.99
200	219.1	300	30
8	8.625	2.07	1.81
250	273.0	300	32
10	10.750	2.07	1.259

Grooved End Cap (Threaded) (GJCP55T)

- Grooved Threaded End Cap is designed to terminate grooved piping end for temporary or permanent basis.
- End Cap Body is made of Ductile Iron confirming to ASTM and Grooving standards AWWA C606 with rated working pressure up to 500 psi.
- Available with hot dipped galvanised coating as optional

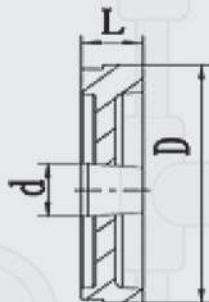

Normal Size mm/in	Pipe O.D mm/in Dimension	Working Pressure PSI/MPa	Dimension L mm/in
100x25	114.3x33.7	500	25
4x1	4.500x1.327	3.45	0.99
150x25	165.1x33.7	500	25
6x1	6.500x1.327	3.45	0.99
150x25	168.3x33.7	500	25
6x1	6.625x1.327	3.45	0.99
200x25	219.1x33.7	500	30
8x1	8.625x1.327	3.45	1.16
250x25	237x33.7	500	32
10x1	10.750x1.327	3.45	1.259



Grade	E		
Temperature Range	-30°F to +230°F -34°C to + 110°C		
Compound	EPDM Conforming to ASTM D2000 (2CA615A25B24F17Z)		
General Service Recommendations	Recommended for hot water service within the specified temperature range plus a variety of dilute acids, oil-free air and many chemical services. UL classified in accordance with ANSI /NSF 61 for cold +86°F (+30°) and hot + 180° F (+82°C) portable water service. Not recommended for petroleum services.		
Chemical Services	Acetaldehyde	Bleach, 12% Active CP	Ethyl Cellulose
	Acetic Acid up to	Borax	Ethyl "cellosolve"
	10% 100°F (38°C)"	Bordeaux Mixture	Ethyl Chloride
	Acetic Anhydride	Boric Add	Ethyl Oxalate
	Acetone	Butanol (see Butyl Alcohol)	Ethylene Chlorohydrin
	Acetophenone	Butyl Acetate	Ethylene Glycol
	Acetylene	Butyl Acetyl Ricinoleate	Ferric Chloride, to 35%
	Alkalis	Butyl Alcohol	Ferric Chloride,
	Allyl Alcohol to 96%	Butyl "Cellosolve Adipate"	Saturated
	Alums	Butyl Phenol	Ferric Hydroxide
	Aluminum Chloride	Butylene Glycol	Fluoboric Acid
	Aluminum Fluoride	Calcium Chloride	Fly Ash
	Aluminum Hydroxide	Calcium Hydroxide (Lime)	Foam
	Aluminum Nitrate	Calcium Hypochlorite	Formaldehyde
	Aluminum Phosphate	Calcium Hypochlorite	Formic Acid
	Aluminum Salts	Calcium Nitrate	Freon 134a, 176°F
	Aluminum Sulfate	Calcium Sulfide	(86°C)
	Ammonia Gas, Cold	Carbitol	Fumaric Acid
	Ammonia Gas, Hot	Carbon Dioxide, Dry	Furfuryl Alcohol
	Ammonia, Liquid	Carbon Dioxide, Wet	Glue
	Ammonium Carbonate	Carbon Monoxide	Glycerin
	Ammonium Fluoride	Caustic Potash	Glycerol
	Ammonium Hydroxide	Cellosolve Acetate	Glycol
	Ammonium Metaphosphate	Cellosolve (Alcohol Ether)	Glycolic Acid
	Ammonium Nitrate	Cellulose Acetate	Halon Hexaldehyde
	Ammonium Persulfate to 10%	Cellulube 220 (Tri-Aryl-Phosphate)	Hydrobromic Acid,
	Ammonium sulfate	Cellulube Hydraulic Fluids	to 40%
	Ammonium Sulfide	Chloric Acid to 20%	Hydrochloric Acid,
	Ammonium Thiocyanate	Chlorine, Water	to 36%, 75°F (240°)
	Ammonium Thioyanate	Chloroacetic Acid	Hydrocyamic Acid
	Amyl Acetate	Chloroacetone	Hydrogn Gas, Cold
	Amyl Alcohol	Citric Acid	Hydrogen Gas, Hot
	Aniline	Copper Fluoride	Hydrogen Sulfide
	Aniline Dyes	Copper Nitrate	Hydroxylamine Sulfate
	Aniline Hydrochloride	Copper Sulfate	Hydrochlorous Acid
	Aniline Oil	Cyclohexanone	Dilute
	Antimony Chloride	Deloniud Water	Isobutyl Alcohol
	Antimony Trichloride	Dlbutyl Phthalat	Isopropyl Acetate
	Argon Gas	Diethyl Sebacate	isopropyl Alcohol
	Barium Carbonate	Diethylene Glycol	Ketones
	Barium Chloride	Dloctyl Phrhalate	Lead Chloride
	Barium Hydroxide	Diozane	Lime and H2O
	Benzaldehyde	Dowtherm SR- I	Magnesium Chloride
	Benzoic Acid	Ethanolamine	Magnesium Hydroxide
	Benzyl Alcohol	Ethyl Acetoacetate	Magnesium Sulfate
	Benzyl Benzoate	Ethyl Alcohol	Mercuric Chloride

Grooved mechanical couplings (GMC) are available in both rigid and flexible models. A rigid coupling is used in applications where a rigid joint is desired, similar to that of a traditional flanged, welded ,or threaded connection.To be considered rigid, a coupling would allow less than one degree of deflection or angular movement.

Flexible couplings are designed to accommodate axial displacement,rotation and a minimum one degree of angular movement. Flexible couplings are used in applications that call for curved or deflected layouts or when systems are exposed to outside forces beyond normal static conditions. such as seismic events or where vibration or noise attenuation are a concern.



RIGID COUPLING - GJRC50G



FLEXIBLE COUPLING - GJFC12G



FLEXIBLE COUPLING HEAVY - GJFC11G



FLEXIBLE COUPLING LARGE SIZE- GJFC12L



RIGID COUPLING LARGE SIZE - GJRC50L

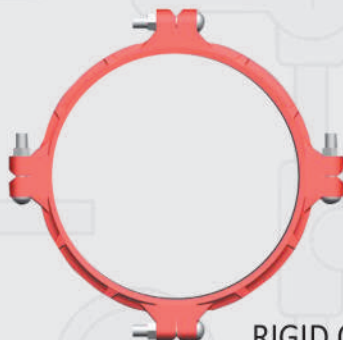

Grooved couplings become less flexible as the pipe size increases.For sizes in excess of 18"(450mm) couplings are very limited in their angular movement.



Before installation, wipe away the burrs, iron rust, greasy dirt on gasket ring and pipe. After cleaning, check whether the groove meets the standard.



Apply a non-petroleum and non-toxic lubricant to gasket ring outside and inside.



Insert the gasket on one end of the pipe and make sure that the gasket does not overhang the pipe fittings ends.



Connect another grooved steel pipe to the other end of the gasket and make sure the gasket rings are at the sealing position of both pipes.



Connect the couplings on the pipe.



Tighten the nuts evenly until specified torque value are achieved.

Warning:

- It is important to tighten the nuts evenly by alternating sides to prevent gasket pinching.
- Proper torquing of bolts is required to obtain specified performance. Over torquing may result bolts or cast broken. Pipe joint separation may result in significant property damage and serious injury.

Required assembly Torques

Bolt Size	Required	Torque
Inch	N.M	Lbs-Ft
3/8	40-60	30-45
1/2	110-135	80-100
5/8	135-175	100-130
3/4	175-245	130-180
7/8	245-325	180-240



WARNING

- Read and understand all instructions before attempting to install any piping products.
- Depressurize and drain the piping system before attempting to install, remove, or adjust any piping products.
- Wear safety glasses, helmet and foot protection during installation.
- Failure to follow these instructions could result in serious personal injury, improper product installation, and/or property damage.

Grovjoint India mechanical tees provide a fast and easy mid-point branch outlet, eliminating the need for welding or the use of multiple fittings.

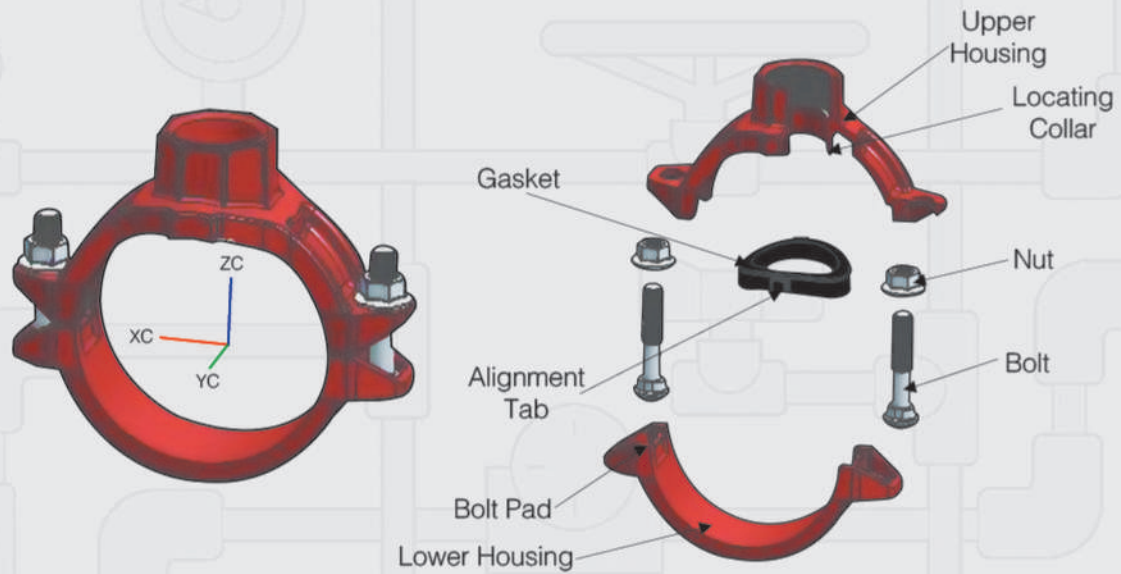

When bolts are tightened with a proper torque, the outlet housing makes metal to metal contact with the outer surface of the pipe.

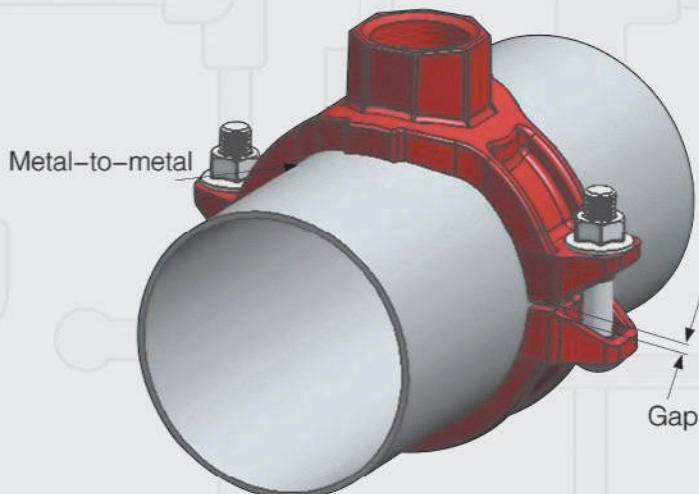

It is normal to see bolt pad gaps, though they should be equal on both sides of the mechanical tee.



Mechanical Tees Installation



Before installation, wipe away the burrs, iron rust, greasy dirt on gasket ring and pipe. Make sure the correct hole saw size is being used. Holes must be drilled on the centerline not on the weld line of the pipe.



Inspect the sealing surface of the gasket and make sure there is no debris present. Lubricate the exposed sealing surface of the gasket.



Insert the gasket in the mechanical tee and make sure the tab in the gasket lines up with the house.



Insert the mechanical tee in the hole.



Install the bottom piece and make sure the locating collar engages the outer hole properly.



Tighten the nuts evenly by alternating sides until the specified torque value is achieved.

Warning:

- It is important to tighten the nuts evenly by alternating sides to prevent gasket pinching.
- Proper torqueing of bolts is required to obtain specified performance. Over torqueing may result bolts or cast broken. Pipe joint separation may result in significant property damage and serious injury.

Required assembly Torques

Bolt Size	Required	Torque
Inch	N.M	Lbs-Ft
3/8	40-60	30-45
1/2	110-135	80-100
5/8	135-175	100-130
3/4	175-245	130-180
7/8	245-325	180-240



WARNING

- Read and understand all instructions before attempting to install any piping products.
- Depressurize and drain the piping system before attempting to install, remove, or adjust any piping products.
- Wear safety glasses, helmet and foot protection during installation.
- Failure to follow these instructions could result in serious personal injury, improper product installation, and/or property damage.

Basic roll groove dimensions conform to ANSI/AWWA C606-06 Table 5 with slightly adjusted tolerances to incorporate international standards including CSA b242, ISO/FDIS 6182-12, Vds 2100-6en and JPF MP-006

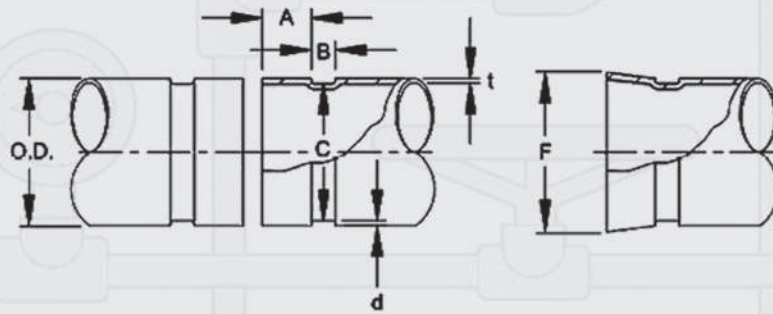

Nominal Size	Basic	Pipe O.D. Tolerance		A	B	C	t	d	F
		In mm	In mm	± 0.030 ± 0.76	± 0.030 ± 0.76	$+0.000$ $+0.00$	Min. Wall	Groove Depth (ref.)	Max. Allowed Flare Dia.
In mm	In mm	In mm	In mm	In mm	In mm	In mm	In mm	In mm	In mm
¾ 20	1.050 26.7	0.26	-0.010 -0.25	0.625 15.88	0.281 7.14	0.938-0.015 23.83-0.38	0.065 1.65	0.056 1.42	1.15 29.21
1 25	1.315 33.4	0.343	-0.013 -0.33	0.625 15.88	0.281 7.14	1.190-0.015 30.23-0.38	0.065 1.65	0.063 1.60	1.43 36.30
1¼ 32	1.660 42.2	0.426	-0.016 -0.41	0.625 15.88	0.281 7.14	1.535-0.015 38.99-0.38	0.065 1.65	0.063 1.60	1.77 44.96
1½ 40	1.900 48.3	0.499	-0.019 -0.48	0.625 15.88	0.281 7.14	1.775-0.015 45.09-0.38	0.065 1.65	0.063 1.60	2.01 51.05
2 50	2.375 60.3	0.634	-0.024 -0.61	0.625 15.88	0.344 8.74	2.250-0.015 57.15-0.38	0.065 1.65	0.063 1.60	2.48 62.99
2½ 65	2.875 73.0	0.769	-0.029 -0.74	0.625 15.88	0.344 8.74	2.720-0.018 69.09-0.46	0.083 2.11	0.078 1.98	0.98 75.69
76.1	3.000 76.1	0.79	-0.030 -0.76	0.625 15.88	0.344 8.74	2.844-0.018 72.24-0.46	0.090 2.30	0.075 1.93	3.10 78.74
3 80	3.500 88.9	0.925	-0.031 -0.79	0.625 15.88	0.344 8.74	3.344-0.018 84.94-0.46	0.083 2.11	0.078 1.98	3.60 91.44
101.6mm	4.000 101.6	1.06	-0.031 -0.79	0.625 15.88	0.344 8.74	3.834-0.020 97.38-0.51	0.083 2.11	0.083 2.11	4.10 104.10
108.0mm	4.250 108.0	1.112	-0.031 -0.79	0.625 15.88	0.344 8.74	4.084-0.020 103.73-0.51	0.083 2.11	0.083 2.11	4.35 110.49
4 100	4.500 114.3	1.06	-0.031 -0.79	0.625 15.88	0.344 8.74	4.334-0.020 110.08-0.51	0.083 2.11	0.083 2.11	4.60 116.84
133.0mm	5.250 133.0	1.371	-0.031 -0.79	0.625 15.88	0.344 8.74	5.084-0.020 129.13-0.51	0.109 2.77	0.083 2.11	5.35 135.89
139.7mm	5.500 139.7	1.45	-0.031 -0.79	0.625 15.88	0.344 8.74	5.333-0.020 135.46-0.51	0.109 2.77	0.083 2.11	5.60 142.24
5 125	5.563 141.3	1.476	-0.031 -0.79	0.625 15.88	0.344 8.74	5.395-0.022 137.03-0.56	0.109 2.77	0.083 2.11	5.66 143.76
159.0mm	6.250 159.0	1.663	-0.031 -0.79	0.625 15.88	0.344 8.74	6.084-0.030 154.53-0.76	0.109 2.77	0.083 2.11	6.35 161.29
165.1mm	6.500 165.1	1.663	-0.031 -0.79	0.625 15.88	0.344 8.74	6.334-0.022 160.88-0.56	0.109 2.77	0.085 2.16	6.60 167.64
6 150	6.625 168.3	1.663	-0.031 -0.79	0.625 15.88	0.344 8.74	6.455-0.022 163.96-0.56	0.109 2.77	0.085 2.16	6.73 170.94
216.3mm	8.516 216.3	1.663	-0.031 -0.79	0.750 19.05	0.469 11.91	8.331-0.025 211.61-0.64	0.109 2.77	0.092 2.34	8.69 220.73
8 200	8.625 219.1	1.663	-0.031 -0.79	0.750 19.05	0.469 11.91	8.441-0.025 214.40-0.64	0.109 2.77	0.092 2.34	8.80 223.52

Nominal Size		Pipe O.D. Tolerance		A	B	C	t	d	F
Basic		Tolerance		± 0.030 ± 0.76	± 0.030 ± 0.76	$+0.000$ $+0.00$	Min. Wall	Groove Depth (ref.)	Max. Allowed Flare Dia.
In mm	In mm	In mm	In mm	In mm	In mm	In mm	In mm	In mm	In mm
10	10.750	+0.063	-0.031	0.750	0.469	10.562-0.027	0.134	0.94	10.92
250	273.0	+1.60	-0.79	19.05	11.91	268.27-0.69	3.40	2.39	277.37
12	12.750	1.663	-0.031	0.750	0.469	12.531-0.030	0.156	0.109	12.92
300	323.9	1.663	-0.79	19.05	11.91	318.29-0.76	3.96	2.77	328.17
14	14.000	1.663	-0.031	0.938	0.469	13.781-0.030	0.156	0.109	14.10
350	355.6	1.663	-0.79	23.83	11.91	350.04-0.76	3.96	2.77	358.14
16	16.000	1.663	-0.031	0.938	0.469	15.781-0.030	0.165	0.109	16.10
400	406.4	1.663	-0.79	23.83	11.91	400.84-0.76	4.19	2.77	408.94
18	18.000	1.663	-0.031	1.000	0.469	17.781-0.030	0.165	0.109	18.16
450	457.2	1.663	-0.79	25.40	11.91	451.64-0.76	4.19	2.77	461.26
20	20.000	1.663	-0.031	1.000	0.469	19.781-0.030	0.188	0.109	20.16
500	508.0	1.663	-0.79	25.40	11.91	502.44-0.76	4.78	2.77	512.06
22	22.000	1.663	-0.031	1.000	0.469	21.656-0.030	0.188	0.172	22.20
550	558.8	1.663	-0.79	25.40	11.91	550.06-0.76	4.78	4.37	563.88
24	24.000	1.663	-0.031	1.000	0.500	23.656-0.030	0.218	0.172	24.20
600	609.6	1.663	-0.79	25.40	12.70	600.86-0.76	5.54	4.37	614.68

1. Pipe ends must be square cut. See above table for maximum allowable tolerances from square cut ends

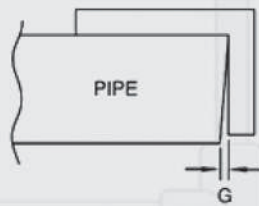

Pipe	G (max)
~3 1/2"	0.030" (0.8mm)
4 ~ 6"	0.045" (1.2mm)
8" ~	0.060" (1.6mm)

2. The gasket seating surface 'A' shall be free from deep scores, marks, or ridges that 'vould prevent a positive seal,

3, The 'O' dimensions are average values. The groove must be of uniform depth around the entire circumference.

4. The 't1 is the minimum allowable wall thickness that may be roll-grooved.groove gage or rule to check the groove diameter.

Acceptance range

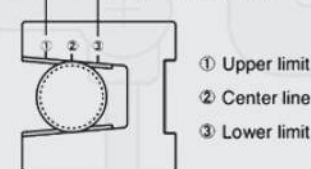

Groove Gage



Groove Rule

5. The 'd' is for reference use only. The groove depth shall be determined by the groove diameter 'C'.

6. Flare Diameter: The pipe end that may flare when the groove is rolled shall be within this limit when measured at the extreme end of the pipe.

Cut Grooving Dimensions

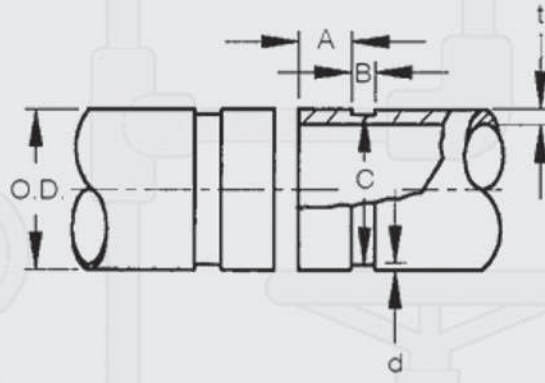

Nominal Size	Basic	Pipe O.D. Tolerance		A	B	C	t	d
		In mm	In mm	± 0.030 ± 0.76	± 0.030 ± 0.76	+0.000 +0.00	Min. Wall	Groove Depth (ref.)
In mm	In mm	In mm	In mm	In mm	In mm	In mm	In mm	In Mm
¾ 20	1.050 26.7	0.26	-0.010 -0.25	0.625 15.88	0.313 7.95	0.938-0.015 23.83-0.38	0.113 2.87	0.056 1.42
1 25	1.315 33.4	0.738	-0.015 -0.38	0.625 15.88	0.313 7.95	1.109-0.015 30.23-0.38	0.133 3.38	0.063 1.60
1 ¼ 32	1.660 42.2	0.769	-0.016 -0.41	0.625 15.88	0.313 7.95	1.535-0.015 38.99-0.38	0.140 3.56	0.063 1.60
1 ½ 40	1.900 48.3	0.499	-0.019 -0.48	0.625 15.88	0.313 7.95	1.775-0.015 45.09-0.38	0.145 3.68	0.063 1.60
2 50	2.375 60.3	0.634	-0.024 -0.61	0.625 15.88	0.131 7.95	2.250-0.015 57.15-0.38	0.154 3.91	0.063 1.60
2 ¼ 65	2.875 73.0	0.769	-0.029 -0.74	0.625 15.88	0.313 7.95	2.720-0.018 69.09-0.46	0.188 4.78	0.078 1.98
76.1 mm	3.000 76.1	0.79	-0.030 -0.76	0.625 15.88	0.313 7.95	2.845-0.018 72.26-0.46	0.188 4.78	0.076 1.93
3 80	3.500 88.9	0.925	-0.031 -0.79	0.625 15.88	0.313 7.95	3.344-0.018 84.94-0.46	0.188 4.78	0.078 1.98
101.6 mm	4.000 101.6	1.06	-0.031 -0.79	0.625 15.88	0.313 7.95	3.834-0.020 97.38-0.51	0.188 4.78	0.078 1.98
108.0 mm	4.250 108.0	1.112	-0.031 -0.79	0.625 15.88	0.375 9.53	4.084-0.020 103.73-0.51	0.203 5.16	0.083 2.11
4 100	4.500 114.3	1.185	-0.031 -0.79	0.625 15.88	0.375 9.53	4.334-0.020 110.08-0.51	0.203 5.16	0.083 2.11
133.0 mm	5.250 133.0	1.372	-0.031 -0.79	0.625 15.88	0.375 9.53	5.084-0.020 129.13-0.51	0.203 5.16	0.083 2.11
139.7 mm	5.500 139.7	1.476	-0.031 -0.79	0.625 15.88	0.375 9.53	5.334-0.022 135.48-0.56	0.203 5.16	0.083 2.11
5 125	5.563 141.3	1.476	-0.031 -0.79	0.625 15.88	0.375 9.53	5.395-0.022 137.03-0.56	0.203 5.16	0.084 2.13
159.0 mm	6.250 159.0	1.663	-0.031 -0.79	0.625 15.88	0.375 9.53	6.084-0.022 154.53-0.56	0.219 5.56	0.083 2.11
165.1 mm	6.500 165.1	1.663	-0.031 -0.79	0.625 15.88	0.375 9.53	6.330-0.022 160.78-0.56	0.219 5.56	0.085 2.16
6 150	6.625 168.3	1.663	-0.031 -0.79	0.625 15.88	0.375 9.53	6.455-0.022 163.96-0.56	0.219 5.56	0.085 2.16
8 200	8.625 219.1	1.663	-0.031 -0.79	0.750 19.05	0.438 11.113	8.441-0.025 214.40-0.64	0.238 6.05	0.092 2.34
10 250	10.750 273.0	1.663	-0.031 -0.79	0.750 19.05	0.500 12.70	10.562-0.027 268.27-0.69	0.250 6.35	0.094 2.39
12 300	12.750 323.9	1.663	-0.031 -0.79	0.750 19.05	0.500 12.70	12.531-0.030 318.29-0.76	0.279 7.09	0.109 2.77



Nominal Size	Basic	Pipe O.D. Tolerance		A	B	C	t	d
		In mm	In mm	± 0.030 ± 0.76	± 0.030 ± 0.76	+0.000 +0.00	Min. Wall	Groove Depth (ref.)
In mm	In mm	In mm	In mm	In mm	In mm	In mm	In mm	In Mm
200 JIS 216.3	8.516 216.3	1.663	-0.031 -0.79	0.750 19.05	0.438 11.13	8.331-0.022 211.61-0.56	0.238 6.05	0.092 2.34
250 JIS 267.4	10.528 267.4	1.663	-0.031 -0.79	0.750 19.05	0.500 12.70	10.339-0.027 262.60-0.69	0.250 6.35	0.094 2.39
300 JIS 318.5	12.539 318.5	1.663	-0.031 -0.79	0.750 19.05	0.500 12.70	12.319-0.030 312.90-0.76	0.279 7.09	0.109 2.77
14 350	14.000 355.6	1.663	-0.031 -0.79	0.938 23.83	0.500 12.70	13.781-0.030 350.04-0.76	0.281 7.14	0.109 2.77
16 400	16.000 406.4	1.663	-0.031 -0.79	0.938 23.83	0.500 12.70	15.781-0.030 400.84-0.76	0.312 7.92	0.109 2.77
18 450	18.000 457.2	1.663	-0.031 -0.79	1.000 25.40	0.500 12.70	17.781-0.030 451.64-0.76	0.312 7.92	0.109 2.77
20 500	20.000 508.0	1.663	-0.031 -0.79	1.000 25.40	0.500 12.70	19.781-0.030 502.44-0.79	0.132 7.92	0.109 2.77
22 550	22.000 558.8	1.663	-0.031 -0.79	1.000 25.40	0.563 14.30	21.656-0.030 550.06-0.76	0.375 9.53	0.172 4.37
24 600	24.000 609.6	1.663	-0.031 -0.79	1.000 25.40	0.562 14.27	23.656-0.030 600.86-0.76	0.375 9.53	0.172 4.37

Pipe O.D. (Column 2):

Maximum allowable tolerances from square of ends is 0.03" for sizes up to 3-1/2" ; 0.045" for 4" tilt-Ai 6" , and 0.060" for sizes 8" and above.

Gasket Seating Surface (Column 3):

The gasket seating surface shall be free from deep scores, marks, or ridges that would prevent a positive seal.

Groove Width (Column 4):

Groove width is to be measured between vertical flanks of the groove side walls.

Groove Diameter (Column 5):

The "C" diameters are average values. The groove must be of uniform depth around the entire pipe circumference.

Minimum Wall Thickness (Column 6):

The "t" is the minimum allowable wall thickness that may be cut-grooved.

Groove Depth (Column 7):

The "d" is for reference use only. The groove dimension shall be determined by the groove diameter "C"



These terms and conditions will control the dealer's readiness to offer Products, or acknowledge a request for Products, to or from Buyer. No waiver, adjustment or change of these terms and conditions whether on Buyer's buy request or in any case will be legitimate except if the waiver, change or alteration is explicitly accepted in writing and signed by an authorized representative of seller.

Delivery

Seller will put forth the vital attempt to finish delivery of items as demonstrated on Seller's acknowledgment of an order but Seller accepts no accountability or liability, and will acknowledge no back charge, for misfortune or harm because of delay or inability to deliver caused by acts of God, war labour challenges, accident, postponements or transporters, by contractors or providers, inability to get materials, deficiencies of fuel and energy, or some other reasons for any kind whatsoever beyond the control of the Seller. Seller may end any agreement of offer of its Products without responsibility of any nature, by written notice to Buyer, if the postponement in the conveyance or execution coming about because of any of the aforementioned causes. Buyer shall be answerable for any extra transportation charges caused by Seller because of Buyer's acts or exclusions.

Price Adjustment

Payments. Prices expressed on Seller's quotes or other documentation offered by Seller are legitimate for 30 days, and do exclude any sales, use, or other taxes unless if explicitly expressed.

Warranty

We warrant all items to be free from defects in materials and workmanship under normal conditions of use and service. Our commitment under this warranty is restricted to repairing or replacing at our premises, if the product has been delivered in the span of one year to the original buyer. The items have to be returned with transportation charges prepaid and our examination have shown that the product is defective.

Liability

Seller won't be at risk for any loss, damage, cost of repairs, accidental or noteworthy harms of any sort, whether based upon warranty (aside from the commitment acknowledged by Seller under "Warranty" above), contract or carelessness, emerging regarding the design, manufacture, sale, use or repair of the products or of the engineering designs provided to Buy

Termination

Seller may terminate this agreement under any condition and whenever by giving Buyer thirty (30) days written notice of termination. Seller may immediately end this agreement, in writing, if Buyer: (a) commits a breach of any provision of this agreement (b) appointment a trustee, receiver or custodian for all or any part of Buyer's property (c) files a petition for relief in bankruptcy on its own behalf, or by a third party (d) makes an assignment for the benefits of creditors, or (e) dissolves or liquidates all or a majority of its assets.

Governing Law

This agreement and the sale and delivery of all Products hereunder shall be deemed to have taken place in and shall be governed and construed in accordance with the laws of Tuticorin Tamil Nadu, as applicable to contracts executed and wholly performed therein and without regard to conflicts of laws principles. Buyer irrevocably agrees and consents to the exclusive jurisdiction and venue of the court of Tuticorin, Tamil Nadu- India with respect to any dispute, controversy or claim arising out of or relating to this agreement.



GROVJOINT INDIA PIPE FITTINGS

GROVJOINT INDIA PIPE FITTINGS

Address: First Floor, 4/28 E-2, K.M.A Warehousing Complex, Harbour Bye
Pass Road, Tuticorin, Thoothukudi-628006, Tamilnadu, India

Tel & Fax : 0461-2900568

E-mail: info@grovejointindia.com

Website: www.grovejointindia.com

DISTRIBUTED BY



JAD AL RIYADH TRADING CO.LTD

Address: King Abdul Azis Road, Sulimaniya, Natcom Building, 2nd Floor,
office #12, Riyadh- Saudi Arabia

Tel: +966 11 217 1101 Fax: +966 11 217 1194

Email: sales@jad.com.sa

Website: www.jad.com.sa